

## PH 201 Homework Assignment Chapter on Torques – 30 Problems Total

1. You are installing a new spark plug in your car, and the manual specifies that it be tightened to a torque that has a magnitude of  $45 \text{ N} \cdot \text{m}$ . Using the data in the drawing, determine the magnitude  $F$  of the force that you must exert on the wrench.

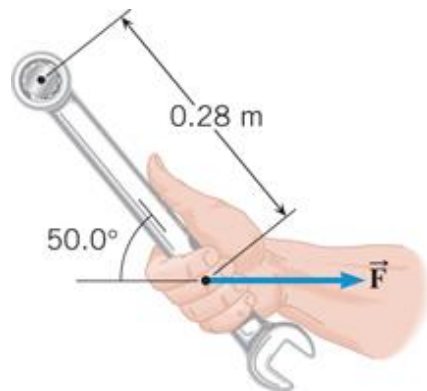

### Solution for Problem 1

2. Two children hang by their hands from the same tree branch. The branch is straight, and grows out from the tree trunk at an angle of  $27.0^\circ$  above the horizontal. One child, with a mass of  $44.0 \text{ kg}$ , is hanging  $1.30 \text{ m}$  along the branch from the tree trunk. The other child, with a mass of  $35.0 \text{ kg}$ , is hanging  $2.10 \text{ m}$  from the tree trunk. What is the magnitude of the net torque exerted on the branch by the children? Assume that the axis is located where the branch joins the tree trunk and is perpendicular to the plane formed by the branch and the trunk.

### Solution for Problem 2

3. One end of a meter stick is pinned to a table, so the stick can rotate freely in a plane parallel to the tabletop. Two forces, both parallel to the tabletop, are applied to the stick in such a way that the net torque is zero. The first force has a magnitude of  $2.00 \text{ N}$  and is applied perpendicular to the length of the stick at the free end. The second force has a magnitude of  $6.00 \text{ N}$  and acts at a  $30.0^\circ$  angle with respect to the length of the stick. Where along the stick is the  $6.00\text{-N}$  force applied? Express this distance with respect to the end of the stick that is pinned.

### Solution for Problem 3

4. A person is standing on a level floor. His head, upper torso, arms, and hands together weigh 438 N and have a center of gravity that is 1.28 m above the floor. His upper legs weigh 144 N and have a center of gravity that is 0.760 m above the floor. Finally, his lower legs and feet together weigh 87 N and have a center of gravity that is 0.250 m above the floor. Relative to the floor, find the location of the center of gravity for his entire body.

**Solution for Problem 4**

5. A hiker, who weighs 985 N, is strolling through the woods and crosses a small horizontal bridge. The bridge is uniform, weighs 3610 N, and rests on two concrete supports, one at each end. He stops one-fifth of the way along the bridge. What is the magnitude of the force that a concrete support exerts on the bridge **(a)** at the near end and **(b)** at the far end?

**Solution for Problem 5**

6. A person exerts a horizontal force of 190 N in the test apparatus shown in the drawing. Find the horizontal force  $\vec{M}$  (magnitude and direction) that his flexor muscle exerts on his forearm.

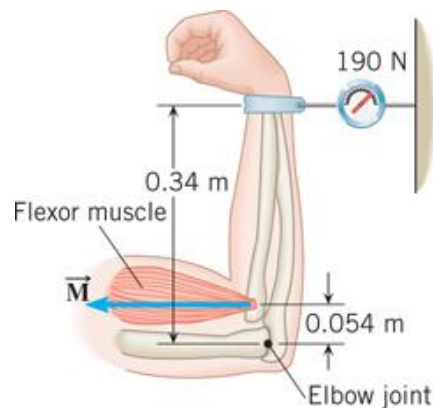

**Solution for Problem 6**

7. The wheels, axle, and handles of a wheelbarrow weigh 60.0 N. The load chamber and its contents weigh 525 N. The drawing shows these two forces in two different wheelbarrow designs. To support the wheelbarrow in equilibrium, the man's hands apply a force  $\vec{F}$  to the handles that is directed vertically upward. Consider a rotational axis at the point where the tire contacts the ground, directed perpendicular to the plane of the paper. Find the magnitude of the man's force for both designs.

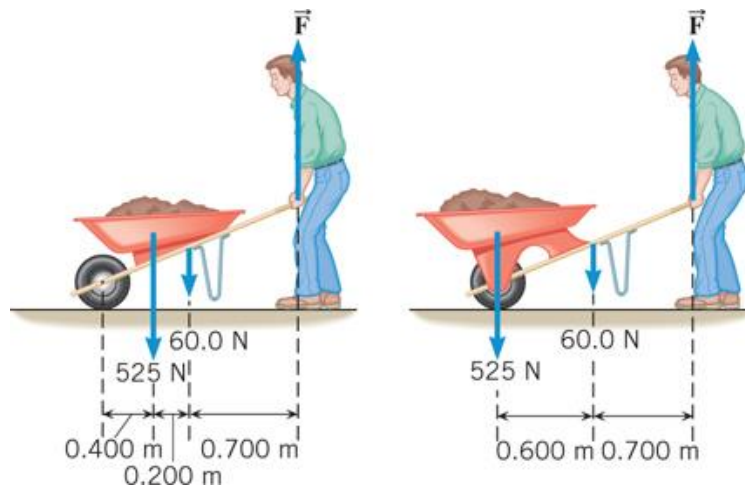

**Solution for Problem 7**

8. The drawing shows a uniform horizontal beam attached to a vertical wall by a frictionless hinge and supported from below at an angle  $\theta = 39^\circ$  by a brace that is attached to a pin. The beam has a weight of 340 N. Three additional forces keep the beam in equilibrium. The brace applies a force  $\vec{P}$  to the right end of the beam that is directed upward at the angle  $\theta$  with respect to the horizontal. The hinge applies a force to the left end of the beam that has a horizontal component  $\vec{H}$  and a vertical component  $\vec{V}$ . Find the magnitudes of these three forces.

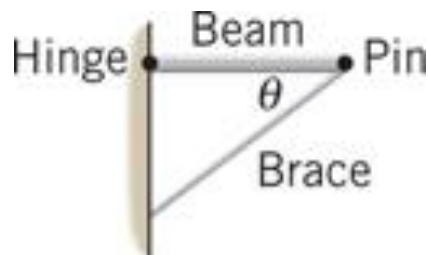

**Solution for Problem 8**

9. A man holds a 178-N ball in his hand, with the forearm horizontal (see the drawing). He can support the ball in this position because of the flexor muscle force  $\vec{M}$ , which is applied perpendicular to the forearm. The forearm weighs 22.0 N and has a center of gravity as indicated. Find (a) the magnitude of  $\vec{M}$  and (b) the magnitude and direction of the force applied by the upper arm bone to the forearm at the elbow joint.

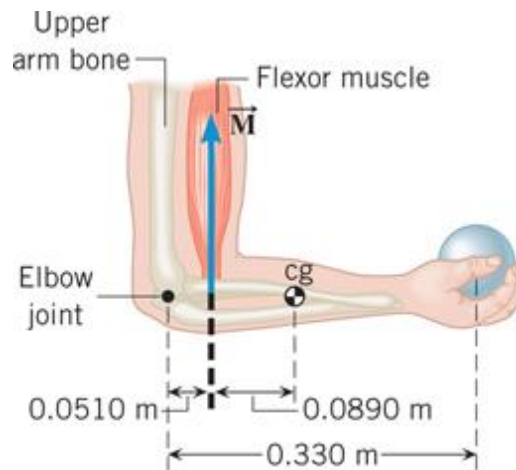

**Solution for Problem 9**

10. A uniform board is leaning against a smooth vertical wall. The board is at an angle  $\theta$  above the horizontal ground. The coefficient of static friction between the ground and the lower end of the board is 0.650. Find the smallest value for the angle  $\theta$ , such that the lower end of the board does not slide along the ground.

**Solution for Problem 10**

11. The drawing shows a bicycle wheel resting against a small step whose height is  $h = 0.120$  m. The weight and radius of the wheel are  $W = 25.0$  N and  $r = 0.340$  m, respectively. A horizontal force  $\vec{F}$  is applied to the axle of the wheel. As the magnitude of  $\vec{F}$  increases, there comes a time when the wheel just begins to rise up and loses contact with the ground. What is the magnitude of the force when this happens?

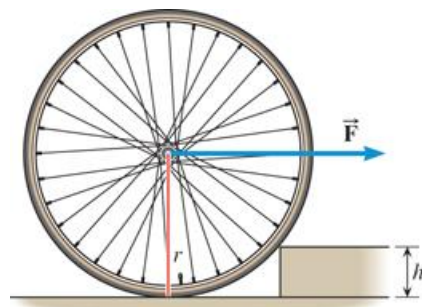

**Solution for Problem 11**

**12.** A 1220-N uniform beam is attached to a vertical wall at one end and is supported by a cable at the other end. A 1960-N crate hangs from the far end of the beam. Using the data shown in the drawing, find **(a)** the magnitude of the tension in the wire and **(b)** the magnitudes of the horizontal and vertical components of the force that the wall exerts on the left end of the beam.

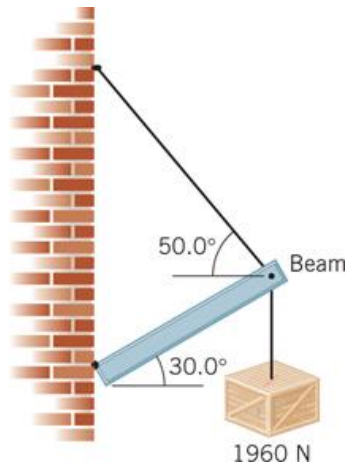

**Solution for Problem 12**

**13.** The drawing shows an A-shaped stepladder. Both sides of the ladder are equal in length. This ladder is standing on a frictionless horizontal surface, and only the crossbar (which has a negligible mass) of the “A” keeps the ladder from collapsing. The ladder is uniform and has a mass of 20.0 kg. Determine the tension in the crossbar of the ladder.

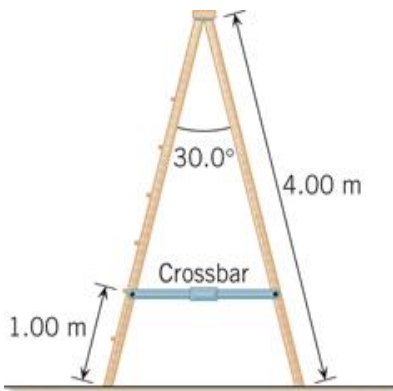

**Solution for Problem 13**

**14.** A CD has a mass of 17 g and a radius of 6.0 cm. When inserted into a player, the CD starts from rest and accelerates to an angular velocity of 21 rad/s in 0.80 s. Assuming the CD is a uniform solid disk, determine the net torque acting on it.

**Solution for Problem 14**

**15.** Two wheels have the same mass and radius of 4.0 kg and 0.35 m, respectively. One has the shape of a hoop and the other the shape of a solid disk. The wheels start from rest and have a constant angular acceleration with respect to a rotational axis that is perpendicular to the plane of the wheel at its center. Each turns through an angle of 13 rad in 8.0 s. Find the net external torque that acts on each wheel.

**Solution for Problem 15**

**16.** The drawing shows a model for the motion of the human forearm in throwing a dart. Because of the force  $\vec{M}$  applied by the triceps muscle, the forearm can rotate about an axis at the elbow joint. Assume that the forearm has the dimensions shown in the drawing and a moment of inertia of  $0.065 \text{ kg} \cdot \text{m}^2$  (including the effect of the dart) relative to the axis at the -elbow. Assume also that the force  $\vec{M}$  acts perpendicular to the forearm. Ignoring the effect of gravity and any frictional forces, determine the magnitude of the force  $\vec{M}$  needed to give the dart a tangential speed of 5.0 m/s in 0.10 s, starting from rest.

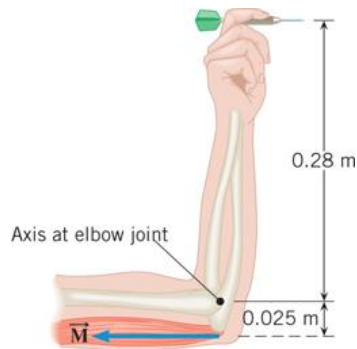

**Solution for Problem 16**

**17.** The drawing shows the top view of two doors. The doors are uniform and identical. Door A rotates about an axis through its left edge, and door B rotates about an axis through its center. The same force  $\vec{F}$  is applied perpendicular to each door at its right edge, and the force remains perpendicular as the door turns. No other force affects the rotation of either door. Starting from rest, door A rotates through a certain angle in 3.00 s. How long does it take door B (also starting from rest) to rotate through the same angle?

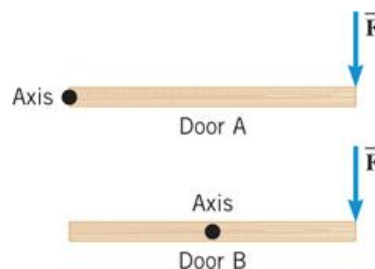

**Solution for Problem 17**

**18.** Calculate the kinetic energy that the earth has because of **(a)** its rotation about its own axis and **(b)** its motion around the sun. Assume that the earth is a uniform sphere and that its path around the sun is circular. For comparison, the total energy used in the United States in one year is about  $1.1 \times 10^{20}$  J.

**Solution for Problem 18**

**19.** A flywheel is a solid disk that rotates about an axis that is perpendicular to the disk at its center. Rotating flywheels provide a means for storing energy in the form of rotational kinetic energy and are being considered as a possible alternative to batteries in electric cars. The gasoline burned in a 300-mile trip in a typical midsize car produces about  $1.2 \times 10^9$  J of energy. How fast would a 13-kg flywheel with a radius of 0.30 m have to rotate to store this much energy? Give your answer in rev/min.

**Solution for Problem 19**

**20.** A helicopter has two blades; each blade has a mass of 240 kg and can be approximated as a thin rod of length 6.7 m. The blades are rotating at an angular speed of 44 rad/s. **(a)** What is the total moment of inertia of the two blades about the axis of rotation? **(b)** Determine the rotational kinetic energy of the spinning blades.

**Solution for Problem 20**

**21.** Starting from rest, a basketball rolls from the top of a hill to the bottom, reaching a translational speed of 6.6 m/s. Ignore frictional losses. **(a)** What is the height of the hill? **(b)** Released from rest at the same height, a can of frozen juice rolls to the bottom of the same hill. What is the translational speed of the frozen juice can when it reaches the bottom?

**Solution for Problem 21**

**22.** A bowling ball encounters a 0.760-m vertical rise on the way back to the ball rack, as the drawing illustrates. Ignore frictional losses and assume that the mass of the ball is distributed uniformly. The translational speed of the ball is 3.50 m/s at the bottom of the rise. Find the translational speed at the top.

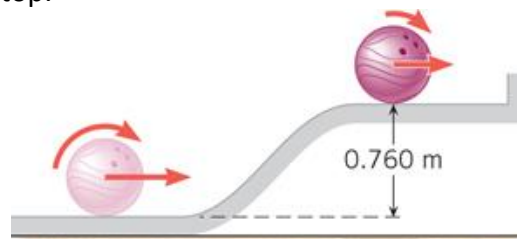

**Solution for Problem 22**

**23.** When some stars use up their fuel, they undergo a catastrophic explosion called a *supernova*. This explosion blows much or all of the star's mass outward, in the form of a rapidly expanding spherical shell. As a simple model of the supernova process, assume that the star is a solid sphere of radius  $R$  that is initially rotating at 2.0 revolutions per day. After the star explodes, find the angular velocity, in revolutions per day, of the expanding supernova shell when its radius is  $4.0R$ . Assume that all of the star's original mass is contained in the shell.

**Solution for Problem 23**

**24.** A playground carousel is free to rotate about its center on frictionless bearings, and air resistance is negligible. The carousel itself (without riders) has a moment of inertia of  $125 \text{ kg} \cdot \text{m}^2$ . When one person is standing on the carousel at a distance of 1.50 m from the center, the carousel has an angular velocity of 0.600 rad/s. However, as this person moves inward to a point located 0.750 m from the center, the angular velocity increases to 0.800 rad/s. What is the person's mass?

**Solution for Problem 24**

**25.** As seen from above, a playground carousel is rotating counterclockwise about its center on frictionless bearings. A person standing still on the ground grabs onto one of the bars on the carousel very close to its outer edge and climbs aboard. Thus, this person begins with an angular speed of zero and ends up with a nonzero angular speed, which means that he underwent a counterclockwise angular acceleration. The carousel has a radius of 1.50 m, an initial angular speed of 3.14 rad/s, and a moment of inertia of  $125 \text{ kg} \cdot \text{m}^2$ . The mass of the person is 40.0 kg. Find the final angular speed of the carousel after the person climbs aboard.

**Solution for Problem 25**

**26.** A small 0.500-kg object moves on a frictionless horizontal table in a circular path of radius 1.00 m. The angular speed is 6.28 rad/s. The object is attached to a string of negligible mass that passes through a small hole in the table at the center of the circle. Someone under the table begins to pull the string downward to make the circle smaller. If the string will tolerate a tension of no more than 105 N, what is the radius of the smallest possible circle on which the object can move?

**Solution for Problem 26**



**27.** The drawing shows a lower leg being exercised. It has a 49-N weight attached to the foot and is extended at an angle  $\theta$  with respect to the vertical. Consider a rotational axis at the knee. **(a)** When  $\theta = 90.0^\circ$ , find the magnitude of the torque that the weight creates. **(b)** At what angle  $\theta$  does the magnitude of the torque equal  $15 \text{ N} \cdot \text{m}$ ?

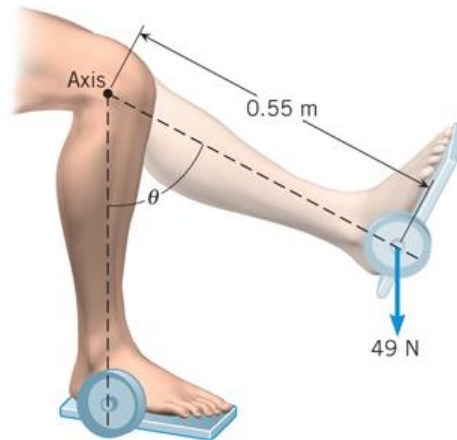

**Solution for Problem 27**

**28.** A uniform plank of length 5.0 m and weight 225 N rests horizontally on two supports, with 1.1 m of the plank hanging over the right support (see the drawing). To what distance  $x$  can a person who weighs 450 N walk on the overhanging part of the plank before it just begins to tip?

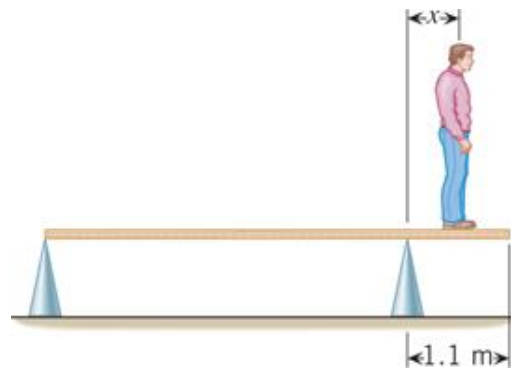

**Solution for Problem 28**

**29.** A rotating door is made from four rectangular sections, as indicated in the drawing. The mass of each section is 85 kg. A person pushes on the outer edge of one section with a force of  $F = 68 \text{ N}$  that is directed perpendicular to the section. Determine the magnitude of the door's angular acceleration.

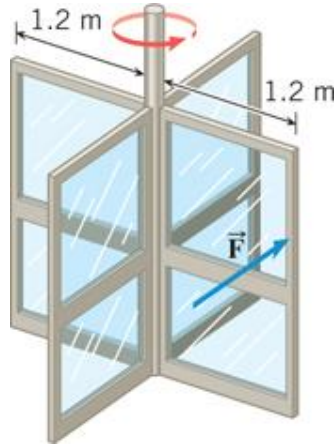

**Solution for Problem 29**

**30.** The drawing shows an outstretched arm (0.61 m in length) that is parallel to the floor. The arm is pulling downward against the ring attached to the pulley system, in order to hold the 98-N weight stationary. To pull the arm downward, the latissimus dorsi muscle applies the force  $\vec{M}$  in the drawing, at a point that is 0.069 m from the shoulder joint and oriented at an angle of  $29^\circ$ . The arm has a weight of 47 N and a center of gravity (cg) that is located 0.28 m from the shoulder joint. Find the magnitude of  $\vec{M}$ .

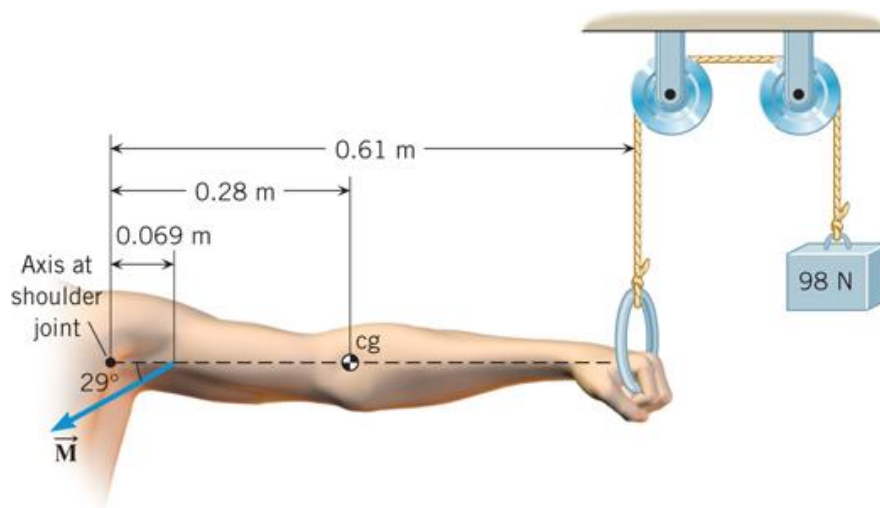

**Solution for Problem 30**

---

**Dr. Donovan's  
Classes Page**

**Dr. Donovan's PH 201  
Homework Page**

**NMU Physics  
Department Web  
Page**

**NMU Main Page**

---

**Please send any comments or questions about this page to  
[ddonovan@nmu.edu](mailto:ddonovan@nmu.edu)**

*This page last updated on November 19, 2021*