

PH 202 Homework Assignment Chapter on Ohm's Law & DC Circuits – 42 Problems Total

1. A defibrillator is used during a heart attack to restore the heart to its normal beating pattern (see Section 19.5). A defibrillator passes 18 A of current through the torso of a person in 2.0 ms. **(a)** How much charge moves during this time? **(b)** How many electrons pass through the wires connected to the patient?

Solution for Problem 1

2. A battery charger is connected to a dead battery and delivers a current of 6.0 A for 5.0 hours, keeping the voltage across the battery terminals at 12 V in the process. How much energy is delivered to the battery?

Solution for Problem 2

3. A coffee-maker contains a heating element that has a resistance of 14 Ω . This heating element is energized by a 120-V outlet. What is the current in the heating element?

Solution for Problem 3

4. Suppose that the resistance between the walls of a biological cell is $5.0 \times 10^9 \Omega$. **(a)** What is the current when the potential difference between the walls is 75 mV? **(b)** If the current is composed of Na^+ ions ($q = +e$), how many such ions flow in 0.50 s?

Solution for Problem 4

5. A car battery has a rating of 220 ampere · hours (A · h). This rating is one indication of the *total charge* that the battery can provide to a circuit before failing. **(a)** What is the total charge (in coulombs) that this battery can provide? **(b)** Determine the maximum current that the battery can provide for 38 minutes.

Solution for Problem 5

6. The resistance of a bagel toaster is 14 Ω . To prepare a bagel, the toaster is operated for one minute from a 120-V outlet. How much energy is delivered to the toaster?

Solution for Problem 6

7. Two wires are identical, except that one is aluminum and one is copper. The aluminum wire has a resistance of 0.20Ω . What is the resistance of the copper wire?

Solution for Problem 7

8. A coil of wire has a resistance of 38.0Ω at 25°C and 43.7Ω at 55°C . What is the temperature coefficient of resistivity?

Solution for Problem 8

9. A tungsten wire has a radius of 0.075 mm and is heated from 20.0 to 1320°C . The temperature coefficient of resistivity is $\alpha = 4.5 \times 10^{-3} (\text{C}^\circ)^{-1}$. When 120 V is applied across the ends of the hot wire, a current of 1.5 A is produced. How long is the wire? Neglect any effects due to thermal expansion of the wire.

Solution for Problem 9

10. A digital thermometer employs a thermistor as the temperature-sensing element. A thermistor is a kind of semiconductor and has a large negative temperature coefficient of resistivity α . Suppose that $\alpha = -0.060 (\text{C}^\circ)^{-1}$ for the thermistor in a digital thermometer used to measure the temperature of a patient. The resistance of the thermistor decreases to 85% of its value at the normal body temperature of 37.0°C . What is the patient's temperature?

Solution for Problem 10

11. An electric blanket is connected to a 120-V outlet and consumes 140 W of power. What is the resistance of the heater wire in the blanket?

Solution for Problem 11

12. There are approximately 110 million households that use TVs in the United States. Each TV uses, on average, 75 W of power and is turned on for 6.0 hours a day. If electrical energy costs $\$0.12$ per kWh, how much money is spent every day in keeping 110 million TVs turned on?

Solution for Problem 12

13. In doing a load of clothes, a clothes dryer uses 16 A of current at 240 V for 45 min . A personal computer, in contrast, uses 2.7 A of current at 120 V . With the energy used by the clothes dryer, how long (in hours) could you use this computer to "surf" the Internet?

Solution for Problem 13

14. The rms current in a copy machine is 6.50 A, and the resistance of the machine is 18.6 Ω . What are **(a)** the average power and **(b)** the peak power delivered to the machine?

Solution for Problem 14

15. The average power used by a stereo speaker is 55 W. Assuming that the speaker can be treated as a 4.0- Ω resistance, find the peak value of the ac voltage applied to the speaker.

Solution for Problem 15

16. Three resistors, 25, 45, and 75 Ω , are connected in series, and a 0.51-A current passes through them. What are **(a)** the equivalent resistance and **(b)** the potential difference across the three resistors?

Solution for Problem 16

17. A 60.0-W lamp is placed in series with a resistor and a 120.0-V source. If the voltage across the lamp is 25 V, what is the resistance R of the resistor?

Solution for Problem 17

18. Multiple-Concept Example 9 reviews the concepts that are important to this problem. A light bulb is wired in series with a 144- Ω resistor, and they are connected across a 120.0-V source. The power delivered to the light bulb is 23.4 W. What is the resistance of the light bulb? Note that there are two possible answers.

Solution for Problem 18

19. Three resistors are connected in series across a battery. The value of each resistance and its maximum power rating are as follows: 2.0 Ω and 4.0 W, 12.0 Ω and 10.0 W, and 3.0 Ω and 5.0 W. **(a)** What is the greatest voltage that the battery can have without one of the resistors burning up? **(b)** How much power does the battery deliver to the circuit in (a)?

Solution for Problem 19

20. A coffee-maker (14 Ω) and a toaster (19 Ω) are connected in parallel to the same 120-V outlet in a kitchen. How much total power is supplied to the two appliances when both are turned on?

Solution for Problem 20

21. The drawing shows three different resistors in two different circuits. The battery has a voltage of $V = 24.0 \text{ V}$, and the resistors have values of $R_1 = 50.0 \Omega$, $R_2 = 25.0 \Omega$, and $R_3 = 10.0 \Omega$. **(a)** For the circuit on the left, determine the current through and the voltage across each resistor. **(b)** Repeat part (a) for the circuit on the right.

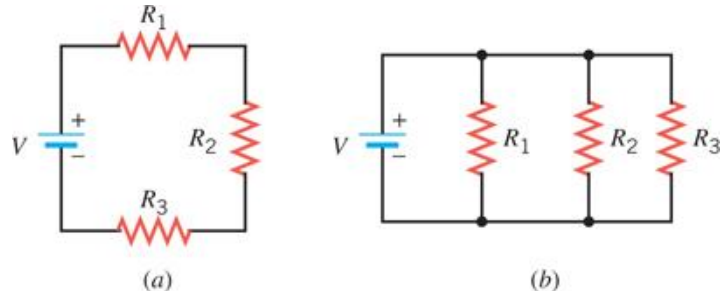

Solution for Problem 21

22. The drawing shows a circuit that contains a battery, two resistors, and a switch. What is the equivalent resistance of the circuit when the switch is **(a)** open and **(b)** closed? What is the total power delivered to the resistors when the switch is **(c)** open and **(d)** closed?

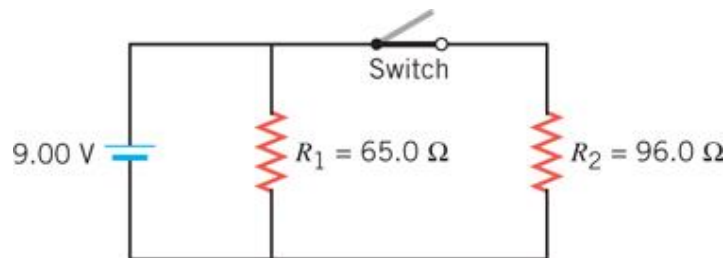

Solution for Problem 22

23. Two resistors, 42.0Ω and 64.0Ω , are connected in parallel. The current through the $64.0\text{-}\Omega$ resistor is 3.00 A . **(a)** Determine the current in the other resistor. **(b)** What is the total power supplied to the two resistors?

Solution for Problem 23

24. A coffee cup heater and a lamp are connected in parallel to the same 120-V outlet. Together, they use a total of 111 W of power. The resistance of the heater is $4.0 \times 10^2 \Omega$. Find the resistance of the lamp.

Solution for Problem 24

25. A $60.0\ \Omega$ resistor is connected in parallel with a $120.0\ \Omega$ resistor. This parallel group is connected in series with a $20.0\ \Omega$ resistor. The total combination is connected across a $15.0\ \text{V}$ battery. Find **(a)** the current and **(b)** the power delivered to the $120.0\ \Omega$ resistor.

Solution for Problem 25

26. A $14\text{-}\Omega$ coffee maker and a $16\text{-}\Omega$ frying pan are connected in series across a 120-V source of voltage. A $23\text{-}\Omega$ bread maker is also connected across the 120-V source and is in parallel with the series combination. Find the total current supplied by the source of voltage.

Solution for Problem 26

27. Find the equivalent resistance between points A and B in the drawing.

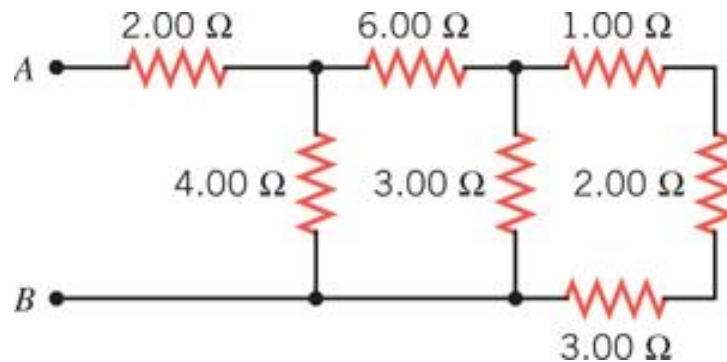

Solution for Problem 27

28. Determine the equivalent resistance between the points A and B for the group of resistors in the drawing.

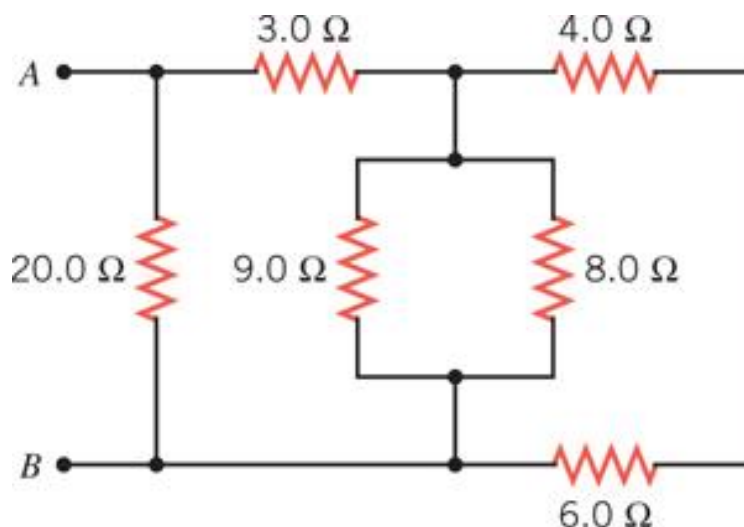

Solution for Problem 28

29. The circuit in the drawing contains five identical resistors. The 45-V battery delivers 58 W of power to the circuit. What is the resistance R of each resistor?

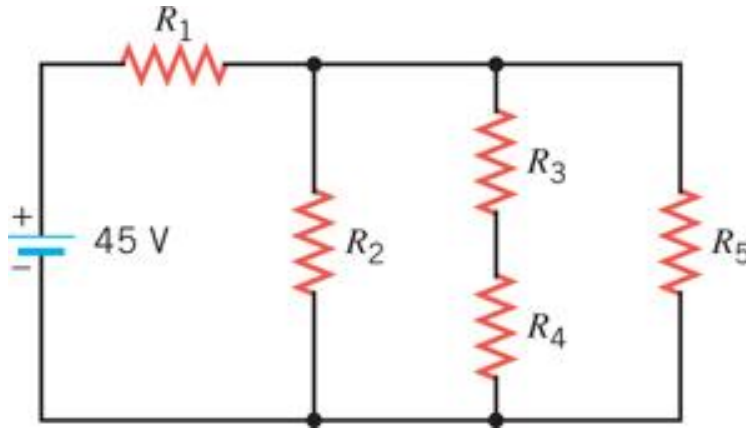

Solution for Problem 29

30. The circuit shown in the drawing is constructed with six identical resistors and an ideal battery. When the resistor R_4 is removed from the circuit, the current in the battery decreases by 1.9 A. Determine the resistance of each resistor.

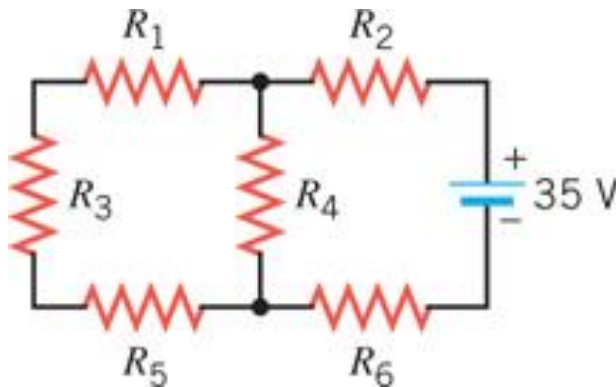

Solution for Problem 30

31. A battery has an internal resistance of 0.50Ω . A number of identical light bulbs, each with a resistance of 15Ω , are connected in parallel across the battery terminals. The terminal voltage of the battery is observed to be one-half the emf of the battery. How many bulbs are connected?

Solution for Problem 31

32. A $1.40\text{-}\Omega$ resistor is connected across a 9.00-V battery. The voltage between the terminals of the battery is observed to be only 8.30 V . Find the internal resistance of the battery.

Solution for Problem 32

33. A battery delivering a current of 55.0 A to a circuit has a terminal voltage of 23.4 V . The electric power being dissipated by the internal resistance of the battery is 34.0 W . Find the emf of the battery.

Solution for Problem 33

34. Consider the circuit in the drawing. Determine (a) the magnitude of the current in the circuit and (b) the magnitude of the voltage between the points labeled A and B . (c) State which point, A or B , is at the higher potential.

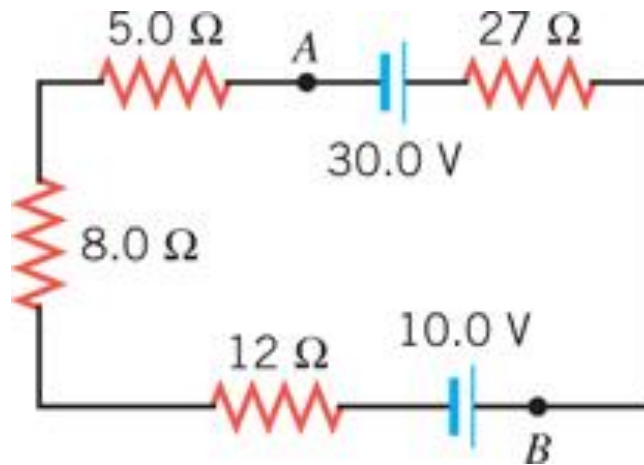

Solution for Problem 34

35. Find the magnitude and the direction of the current in the $2.0\ \Omega$ resistor in the drawing.

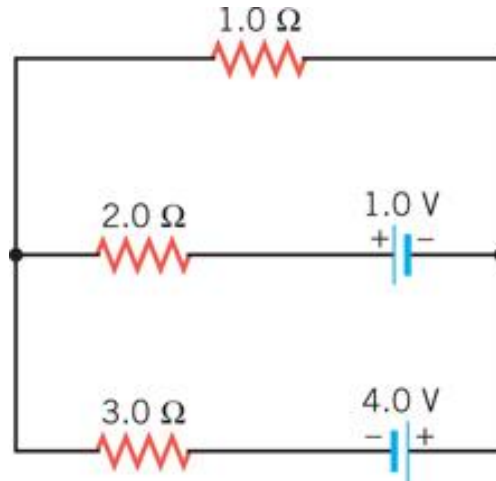

Solution for Problem 35

36. Determine the voltage across the $5.0\ \Omega$ resistor in the drawing. Which end of the resistor is at the higher potential?

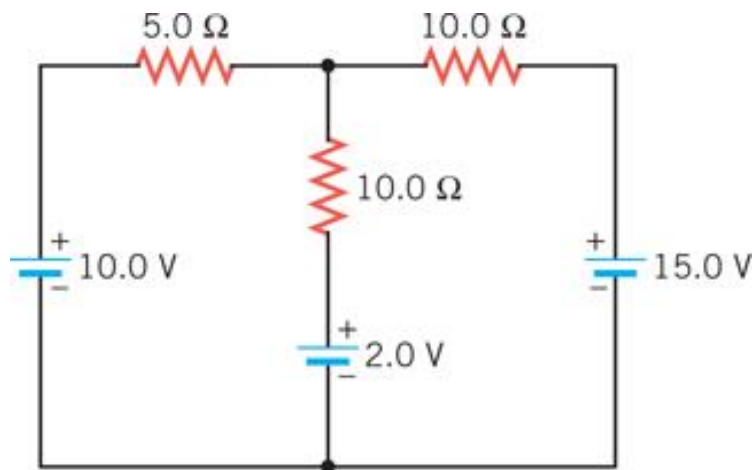

Solution for Problem 36

37. None of the resistors in the circuit shown in the drawing is connected in series or in parallel with one another. Find (a) the current I_5 and the resistances (b) R_2 and (c) R_3 .

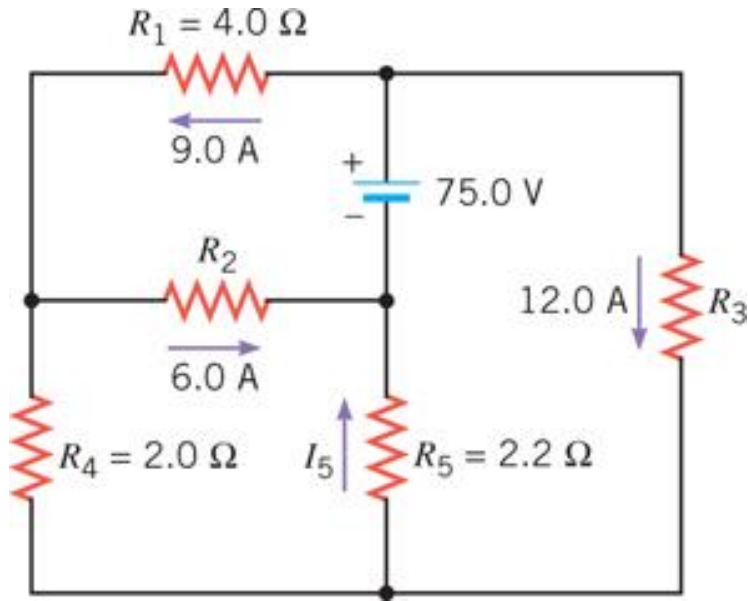

Solution for Problem 37

38. Two capacitors are connected to a battery. The battery voltage is $V = 60.0 \text{ V}$, and the capacitances are $C_1 = 2.00 \mu\text{F}$ and $C_2 = 4.00 \mu\text{F}$. Determine the total energy stored by the two capacitors when they are wired (a) in parallel and (b) in series.

Solution for Problem 38

39. Determine the equivalent capacitance between A and B for the group of capacitors in the drawing.

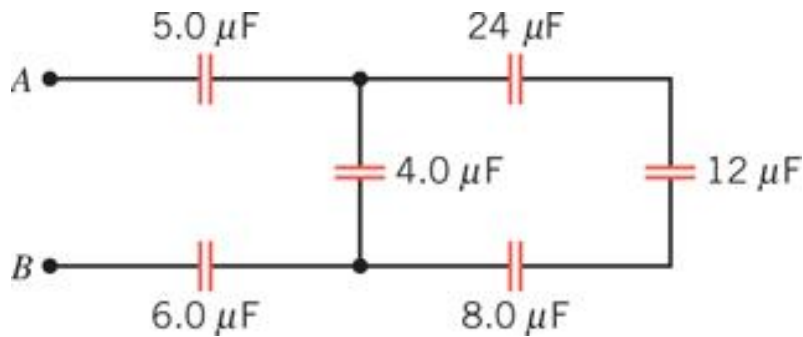

Solution for Problem 39

40. The drawing shows two capacitors that are fully charged ($C_1 = 2.00 \mu\text{F}$, $q_1 = 6.00 \mu\text{C}$; $C_2 = 8.00 \mu\text{F}$, $q_2 = 12.0 \mu\text{C}$). The switch is closed, and charge flows until equilibrium is reestablished (i.e., until both capacitors have the same voltage across their plates). Find the resulting voltage across either capacitor.

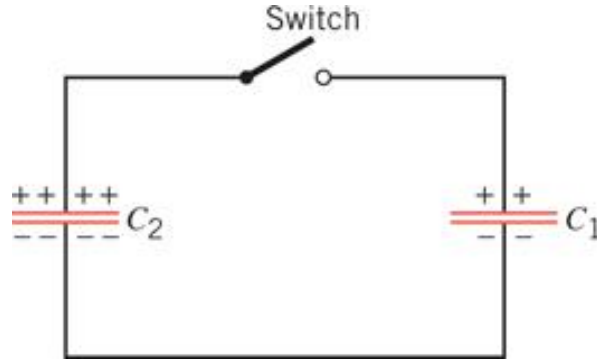

Solution for Problem 40

41. In a heart pacemaker, a pulse is delivered to the heart 81 times per minute. The capacitor that controls this pulsing rate discharges through a resistance of $1.8 \times 10^6 \Omega$. One pulse is delivered every time the fully charged capacitor loses 63.2% of its original charge. What is the capacitance of the capacitor?

Solution for Problem 41

42. The circuit in the drawing contains two resistors and two capacitors that are connected to a battery via a switch. When the switch is closed, the capacitors begin to charge up. What is the time constant for the charging process?

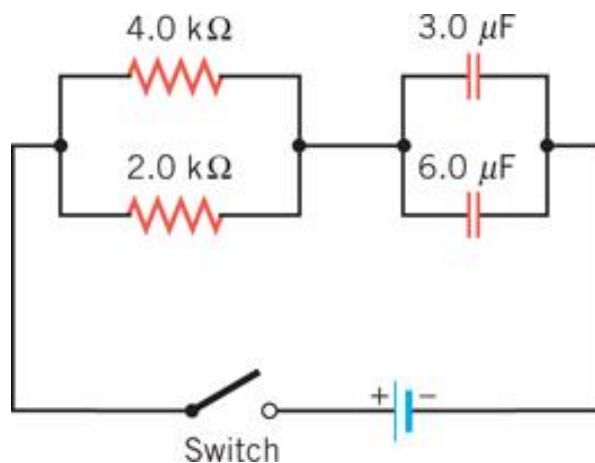

Solution for Problem 42

Dr. Donovan's
Classes Page

Dr. Donovan's PH 202
Homework Page

NMU Physics
Department Web
Page

NMU Main Page

Please send any comments or questions about this page to
ddonovan@nmu.edu

This page last updated on January 6, 2021