

Ohm's Law

Ohm's law is a relationship between three fundamental properties of electrical components: The current (i) passing through the component, the voltage (V) across the element and the opposition to the current flow through the element known as the resistance (R). Ohm's law is usually expressed in one of the following forms:

$$i = \frac{V}{R}$$

$$V = iR$$

$$R = \frac{V}{i}$$

Considering the first relation

$$i = \frac{V}{R}$$

If you were to collect data of voltages and currents and plot voltages on the x axis and current created due to the voltage across the resistor on the y axis, you would have a linear relation and the slope of the plot would be the reciprocal of the resistance of the resistor. This is what the first experiment will have you do. Please remember that currents are measured through a part and so the ammeter should be wired in series with the part as shown in the diagram below. Voltages are measured across the part so voltmeters should be wired in parallel with the part. Have your instructor check your circuit if you are unsure.

Experiment 1: $i - V$ Curve Finding a Resistance

Wire up the following circuit:

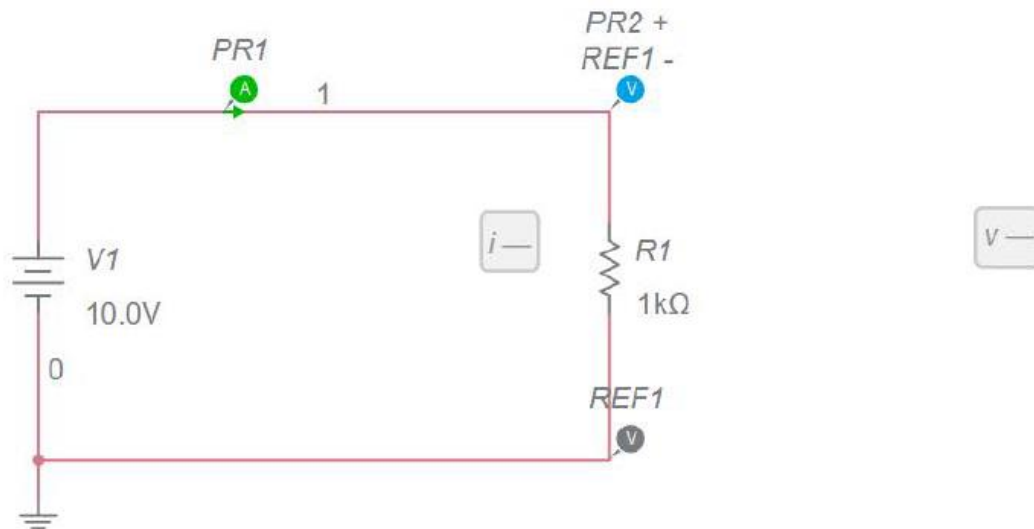

Complete table 01 in the Worksheet you will turn in for this lab.

Note the Nominal $V_{applied}$ is the approximate value you should get close to. The actual $V_{applied}$ is what you get so it is likely 1.08, 1.12 or 0.94 etc. don't spend lots of time trying to get exactly 1.00.

Create an x-y scatter plot without lines and plot $V_{applied}$ on the x axis and $i_{measured}$ on the y axis. Be sure to format plot correctly including title axis labels etc. Put a linear trend line on the plot, format the equation correctly, and put the R^2 value as well. The resistance of the resistor can be found from taking the reciprocal of the slope.

Proper Axis labels would look like:

Voltage Across, V, (V)

and

Current Through, i, (mA)

A Properly Formatted Trend Line would look like:

$$i = (1.203 \text{ mA/V}) V - 0.324 \text{ mA}$$

Now, the units for slope should be $\frac{\text{mA}}{\text{V}} = \frac{1}{\text{k}\Omega}$ so when you take the reciprocal your resistance will have units of $\text{k}\Omega$!

Print out a **Full-Page** plot and Print out the spreadsheet.

Complete table 02 in the Worksheet you will turn in for this lab.

Experiment 2: Resistors wired in Series

When electrical components are wired in series, the same current in one part must be the same current in the next part. So when we consider what the total voltage change across two or more parts will be

$$V_{total} = V_1 + V_2 + \dots + V_n$$

Using the second relation of Ohm's law from above we can rewrite this as:

$$i_{total}R_{total} = i_1R_1 + i_2R_2 + \dots + i_nR_n$$

But

$$i_{total} = i_1 = i_2 = i_n$$

So we can cancel that out and

For resistors in series we have

$$R_{total} = R_1 + R_2 + \dots + R_n$$

Wire up the following circuit:

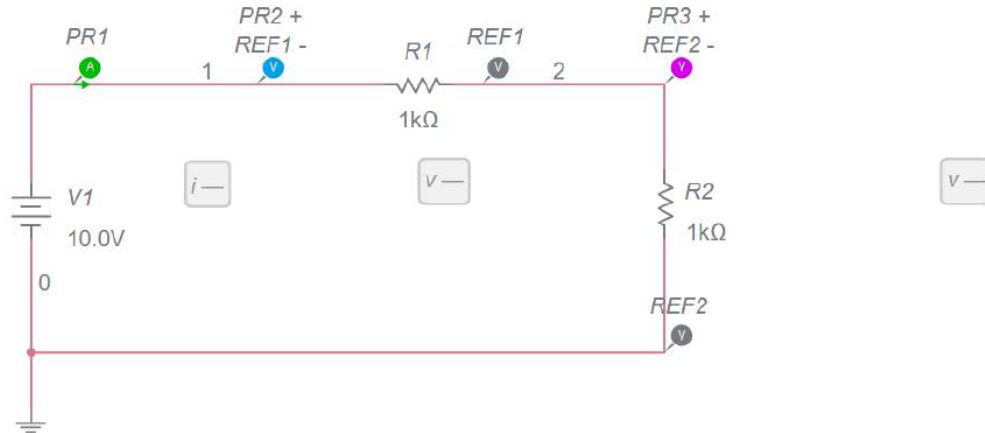

Complete table 03 in the Worksheet you will turn in for this lab.

For the %diff values use the relationship:

$$\%diff = \frac{R_{add} - R_{calc}}{R_{add}} \times 100$$

Experiment 3: Resistors wired in Parallel

When electrical components are wired in parallel, the same voltage across one part must be the same as the voltage across the next part. So when we consider what the total current through two or more parts will be

$$i_{total} = i_1 + i_2 + \dots + i_n$$

Using the first relation of Ohm's law from above we can rewrite this as:

$$\frac{V_{total}}{R_{total}} = \frac{V_1}{R_1} + \frac{V_2}{R_2} + \dots + \frac{V_n}{R_n}$$

But

$$V_{total} = V_1 = V_2 = V_n$$

So we can cancel that out and

For resistors in parallel we have

$$\frac{1}{R_{total}} = \frac{1}{R_1} + \frac{1}{R_2} + \dots + \frac{1}{R_n}$$

Wire up the following circuit:

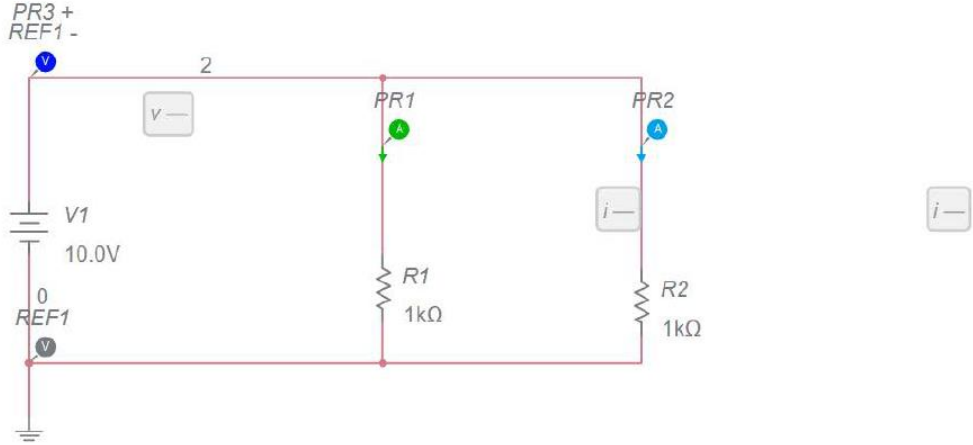

Complete table 04 in the Worksheet you will turn in for this lab.

For the %diff values use the relationship:

$$\%diff = \frac{R_{add} - R_{calc}}{R_{add}} \times 100$$