

PH 220 Homework Assignment Chapter on Forces – 31 Problems Total

1. An astronaut has a mass of 73.0 kg. Determine their weight on:

- (a) on Earth ($g_E = 9.80 \text{ m/s}^2$)
- (b) on the Moon ($g_{\text{Moon}} = 1.70 \text{ m/s}^2$)
- (c) on Mars ($g_{\text{Mars}} = 3.70 \text{ m/s}^2$)
- (d) in outer space far from any other objects traveling at constant speed ($g_{\text{Outer}} = 0.00 \text{ m/s}^2$)

Solution for Problem 1

2. A train has a mass of $4.70 \times 10^5 \text{ kg}$ and is traveling with a constant velocity of $\vec{v}_0 = 38.9 \text{ m/s}$ ($\widehat{\text{East}}$). When the train is 225. m from a stalled car on a railroad crossing, Superman meets the train to bring it to a stop just before it collides with the stalled car.

- (a) What is the magnitude and direction of the force Superman applies to the train to bring it to rest?
- (b) How does the magnitude of this force compare to the weight of the train?
- (c) What is the magnitude and direction of the force the train exerts on Superman?
- (d) How does the magnitude of this force compare to the weight of Superman (assume a mass of 90.9 kg)?

Solution for Problem 2

3. A truck is traveling with a velocity of $\vec{v}_0 = 120 \text{ km/h}$ ($\widehat{\text{South}}$). The driver applies the brakes on the truck and brings the rig to rest in a time of 9.23 s. Knowing the mass of the truck and driver is $1.94 \times 10^4 \text{ kg}$, what is the magnitude and direction of the average force the brakes used to accomplish this?

Solution for Problem 3

4. A baseball is moving with a velocity of 41.3 m/s (*Right*) when it collides with the catcher's mitt catching it. The catcher's mitt is moved 12.0 cm (*Right*) bring the ball whose mass is 0.140 kg to rest. What is the magnitude and direction of the average force exerted on the ball by the catcher's mitt?

Solution for Problem 4

5. A construction crane uses a steel cable that can safely provide a tension force of $1.64 \times 10^4 \text{ N}$. The crane is raising a massive concrete slab to be installed for a highway bridge. If the crane is causing the slab to be accelerated upward with an acceleration of 3.32 m/s^2 , what is the greatest mass the slab may possess that will not break the cable?

Solution for Problem 5

6. Can an object stop on a dime? Consider a car $m_{\text{car}} = 1350. \text{ kg}$ is going to stop over a distance the diameter of a dime $d = 1.70 \times 10^{-2} \text{ m}$. Assume the car was traveling with an initial speed of $11.1 \text{ m/s} \sim 40 \text{ km/h}$. Assume the driver has a mass of $m_{\text{driver}} = 69.0 \text{ kg}$.

- (a) Calculate the average acceleration needed for the car to "Stop on a Dime".
- (b) Determine how many "g's" this is.
- (c) What is the average force exerted on the driver by the car's restraining system (seatbelts?) as the car comes to a stop?

Solution for Problem 6

7. The cable supporting an elevator car which has a mass of $2.75 \times 10^3 \text{ kg}$ can provide a maximum of tension of $2.89 \times 10^4 \text{ N}$ before the cable fails. What is the greatest upward acceleration the cable can provide this elevator car?

Solution for Problem 7

8. A person wanting to show off for their friends walks off the edge of an unfilled pool and lands on their feet. When they strike the bottom of the pool they bend their knees so their torso (body excluding legs) decelerates over a distance of 0.650 m. The height from the edge to the bottom is 2.74 m. Assume the mass of the torso is 44.0 kg.

- (a) What is the person's speed just before their feet touch the bottom of the pool?
- (b) What is the average force(magnitude and direction) exerted on the torso by their legs during the deceleration?

Solution for Problem 8

9. A crate weighs $W_1 = 84.0$ N and rests on the floor as shown on the right. A massless, stretchless and unbreakable rope is attached to the crate and goes up over a massless and frictionless pulley. The rope then attaches to a box with a weight W_2 . Determine the force the floor exerts on the crate when:

- (a) $W_2 = 15.0$ N
- (b) $W_2 = 58.0$ N
- (c) $W_2 = 84.0$ N
- (d) $W_2 = 92.0$ N

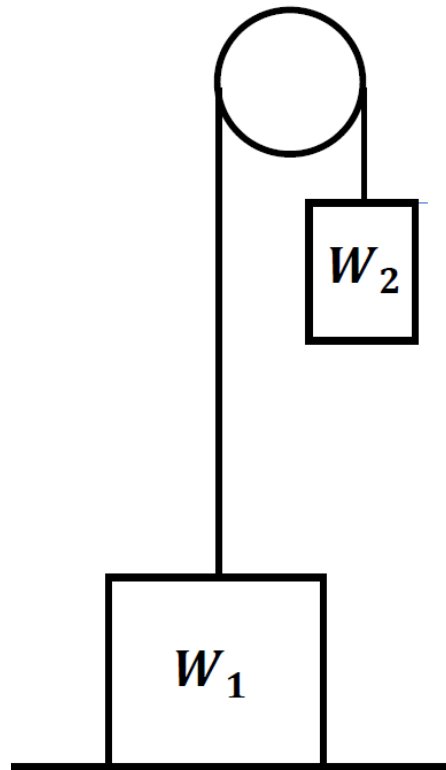

Solution for Problem 9

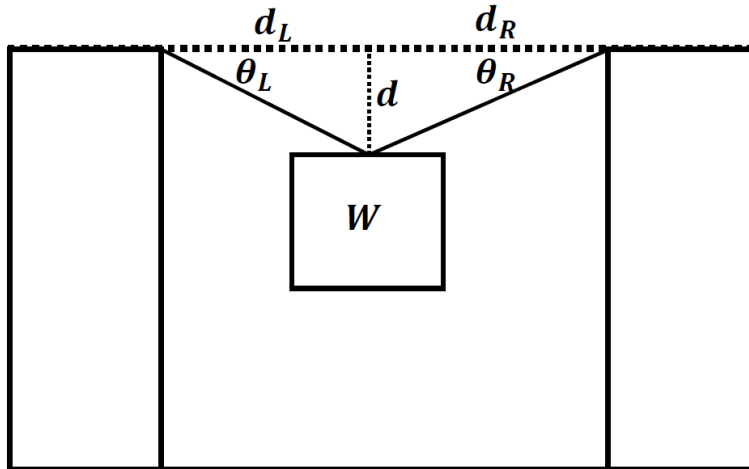

10. A “Tyrolean Traverse” is an alpine device to aid people from traveling between two high points in the mountains. Assume one is set up between two skyscrapers in a city. Assume the distance between the two buildings is 30.0 m. Using a harness, a person can go along the cable from one building to the next. The cable used must sag to reduce the tension in the cable. At the midpoint ($d_L = d_R$ and $\theta_L = \theta_R$) the sag is the variable d . The maximum tension the cable can support before breaking is 8.37×10^4 N. To be extremely safe, assume a safety factor of 10 X. This means assume the cable breaks with a value of 8.37×10^3 N. The mass of the rider and harness equipment used for the “Tyrolean Traverse” is 130. kg.

- (a) What is the distance of sag (d) needed for the tension to be below the safety range of 8.37×10^3 N?
- (b) What if the “Tyrolean Traverse” is not installed correctly and the sag is one third the amount found in part (a) will the cable hold?

Solution for Problem 10

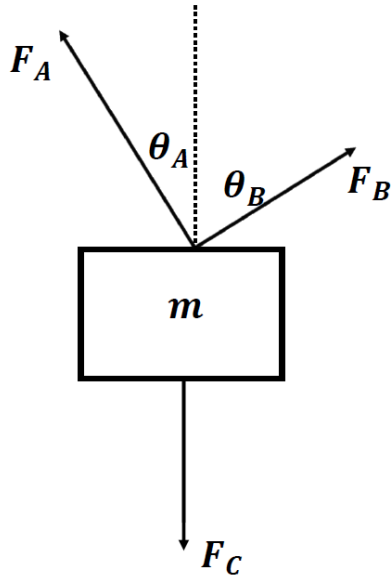

11. As shown on the left a crate which has a mass ($m = 203. \text{ kg}$) has three cables attached to it as it sits on a frictionless surface as shown in a view looking down on the setup. Force A is $F_A = 2110 \text{ N}$ while the angle shown is $\theta_A = 33.0^\circ$. The angle $\theta_B = 57.0^\circ$. The net force on the crate is zero and the crate does not move on the frictionless surface it rests on.

- (a) What is the magnitude of F_B ?
- (b) What is the magnitude of F_C ?

Solution for Problem 11

12. As shown below trucks often pull two or sometimes even three trailers to make a long-distance truck trip more profitable. Consider the truck below. The cab has a mass of $m_{\text{cab}} = 7.10 \times 10^3 \text{ kg}$ each trailer has a mass $m_{\text{Trailer}} = 3.60 \times 10^4 \text{ kg}$. We will examine a cab pulling two trailers that is accelerating at some constant acceleration $a = 2.29 \text{ m/s}^2$.



<https://www.freeimages.com/premium/double-articulated-truck-959358>

- (a) What is the magnitude of the tension force in the coupling between trailer 1 and trailer 2 F_{T2} ?
- (b) What is the magnitude of the tension force in the coupling between the cab and trailer 1 F_{T1} ?
- (c) What is the magnitude of the engine force for the cab to provide the cab and trailers with the acceleration $a = 2.29 \text{ m/s}^2$

Solution for Problem 12

13. A sprinter exerts a force of 670. N @ 19.0° below the horizontal on a racing starting block. The sprinter has a mass of 57.0 kg. Assume the starting block is massless.

- (a) What is the magnitude of the horizontal acceleration the sprinter created?
- (b) If the foot remained in contact with the block for a time of 0.270 s, what is the speed the sprinter left the block with?
- (c) What is the magnitude of the normal force the ground exerts on the sprinter while their foot remains in contact with the starting block?

Solution for Problem 13

14. A mass ($m = 4.45$ kg) has two forces acting on it.:

$$\vec{F}_1 = (12\hat{i} + 16\hat{j})\text{N} \quad \vec{F}_2 = (10\hat{i} - 32\hat{j})\text{N}$$

The object is at rest at $t = 0.00$ s. What is the velocity at $t = 2.89$ s?

Solution for Problem 14

15. A baseball player (72.1 kg) is running to second base with a speed of 8.33 m/s. When the runner is 2.20 m from the base, he starts his slide coming to rest at the base. What is the average force the infield dirt exerts on the runner during his slide?

Solution for Problem 15

16. Joan has a pair of roller skates on and is moving with an initial speed of 1.64 m/s down the incline plane shown below. Assume there is no friction for the roller skates or air resistance acting on her as she descends the incline. Joan ends up traveling a length of 26.0 m in a time of 4.17 s . At what angle (θ) is the plane inclined to the horizontal?

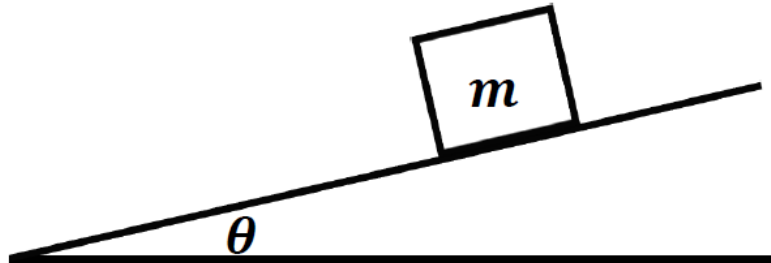

Solution for Problem 16

17. Three blocks are at rest on a frictionless horizontal surface as shown below. The blocks remain in constant contact with each other as a force \vec{F}_A is applied to block 3 as indicated.

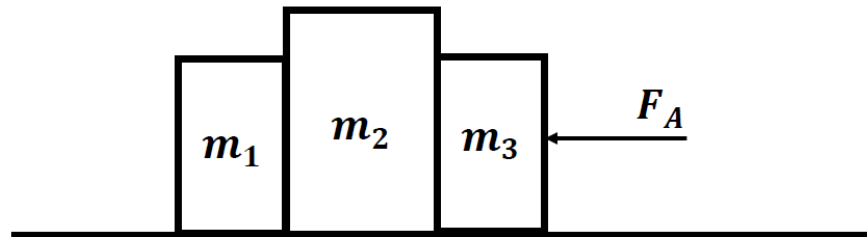

- (a) Draw a free body diagram for each block separately.
- Determine:
- (b) The acceleration of the system of blocks in terms of m_1 , m_2 , m_3 , and F_A .
 - (c) The net force on each block
 - (d) The force of contact that each block exerts on its neighboring blocks.
 - (e) Numerical values for parts (b), (c), and (d) if we use $m_1 = m_2 = m_3 = 15.0 \text{ kg}$ and $F_a = 120. \text{ N}$
 - (f) Provide some comments to explain whether or not the numerical answers make "sense".

Solution for Problem 17

18. The figure below shows two masses connected by a massless, stretchless, and unbreakable cable. Mass m_A is at rest on a frictionless table. Mass m_B is at rest hanging in the air. The cable rides on a massless frictionless pulley. When ready the masses are allowed to move.

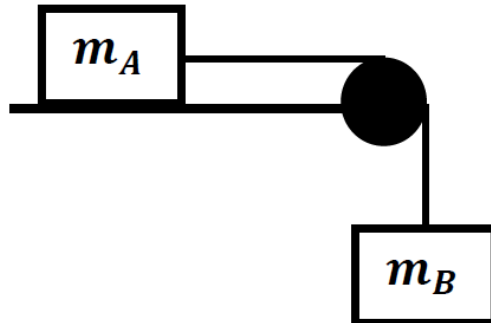

- (a) Draw a free body diagram for each block separately.
- Determine:
- (b) The acceleration of the system of blocks in terms of m_A , m_B , and g .
- (c) The tension in the cable again in terms of m_A , m_B , and g .

Solution for Problem 18

19. A small block with a mass m_s rests on the incline plane part of a triangular shaped block of mass m_T . The triangular mass sits on a horizontal surface. All surfaces are frictionless. Derive an expression that the applied force F must have so that the small block remains at its initial relative position on the triangular block as the system is moving.

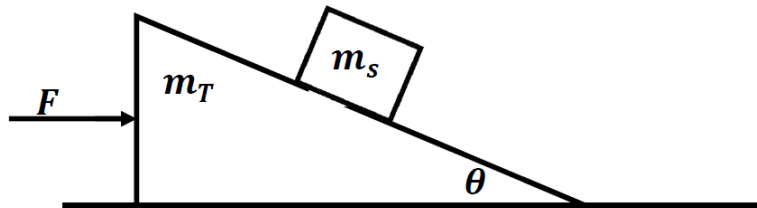

Hint: use x and y coordinates instead of perpendicular and parallel components.

Solution for Problem 19

20. As shown to the right two masses ($m_1 = 1.89 \text{ kg}$) and ($m_2 = 3.07 \text{ kg}$) are connected by a massless, stretchless, and unbreakable rope. The two masses start at a height ($d_s = 2.30 \text{ m}$) above the floor. The rope passes over a massless, frictionless pulley whose center is located ($d_p = 9.20 \text{ m}$) above the floor. When the masses are allowed to move, clearly the larger mass will fall to the floor. Once this mass is on the floor, the tension in the rope will go to zero and the lighter mass is essentially flung upwards until either gravity slows it to zero or it gains enough height for the rope to have non-zero tension again. Determine how far above the floor the lighter mass will reach before it begins to fall back towards the floor.

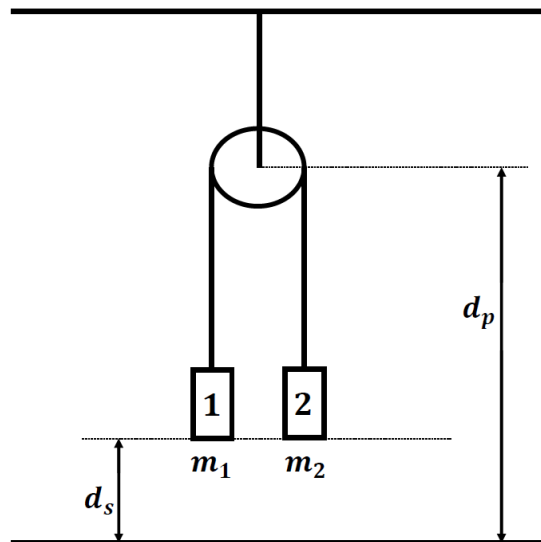

Solution for Problem 20

21. A brief case contains \$10,000 dollars and has a mass of 10.0 kg. By accident the brief case is dropped from rest from the Grand Canyon Skywalk and falls a distance 200. m before striking the ground below. The speed of the brief case just before it strikes the ground is 23.6 m/s . What was the average force of air resistance that acted on the brief case as it fell?

Solution for Problem 21

22. An 85.0 kg person is standing on a weight scale which is also on an elevator. Determine what the scale reads in both Weight (N) and Mass (kg) for each situation below:

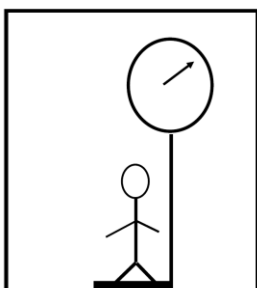

- (a) The elevator is at rest.
- (b) The elevator is rising at a constant speed of 2.50 m/s .
- (c) The elevator is descending at a constant speed of 1.75 m/s .
- (d) The elevator is descending with a constant acceleration of 3.15 m/s^2 .
- (e) The elevator is rising with a constant acceleration of 4.87 m/s^2 .

Solution for Problem 22

23. A bicyclist and her bike has a combined mass of 77.0 kg. She coasts down a hill which has an angle of incline equal to $\theta = 5.56^\circ$ at a speed of 4.76 km/h . This constant speed is due to the action of air resistance on her. Now assume she climbs the same hill at the same speed and experiences the same air resistance. How much force must the bike exert to accomplish this?

Solution for Problem 23

24. As shown on the right, a pair of pulleys are set up to reduce the force needed to raise or lower a large mass (m). Assume the mass is raised or lowered at a constant speed. Find the tensions required in the different sections of rope. Assume the rope is massless, stretchless and unbreakable. Assume the pulleys are massless and frictionless.

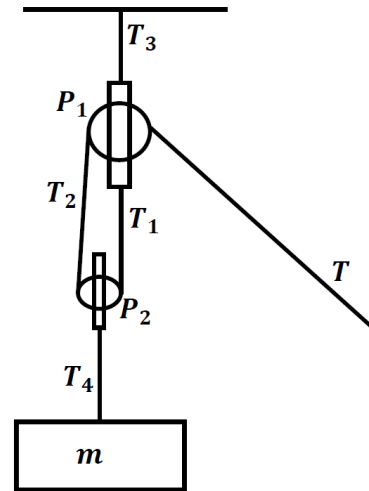

Solution for Problem 24

25. Sometimes when two buildings are connected the corresponding floors do not join on a level. One floor is above or below the other by a small amount. This can make moving equipment between the two building parts awkward when dealing with the height changes even though the floors are essentially ramps. See the figure below. One company decided their employees could move equipment if the maximum force they had to exert going up a ramp, was at most 20.0 N. What is the maximum angle the ramp can be inclined to for an employee to move a piece of equipment with a mass of 35.0 kg. Assume the equipment is moved at constant speed. Assume no friction issues.

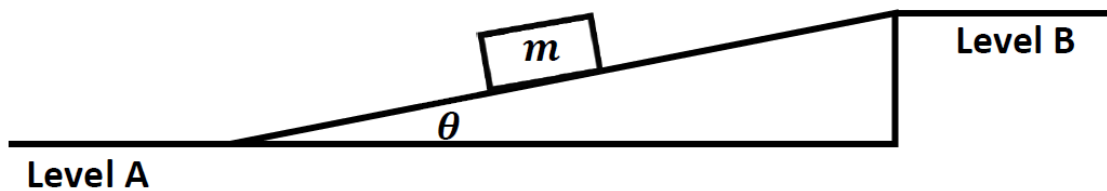

Solution for Problem 25

26. A helicopter ($m_{\text{Helo}} = 8320. \text{ kg}$) is rising upward with an acceleration of 0.675 m/s^2 . The helicopter is attached to a housing structure ($m_{\text{Struct}} = 3160. \text{ kg}$) with a massless, stretchless, and unbreakable cable.

- (a) What is the lift force exerted on the blades of the helicopter by the air?
- (b) What is the tension force in the cable being used to lift the housing structure?

Solution for Problem 26

27. In a tall skyscraper, a high-speed elevator reaches a speed of 4.47 m/s when the elevator car whose mass including riders is $1750. \text{ kg}$ is rising up the building. What is the tension in the cable used to move the elevator car if the car needs to slow down and stop over a distance of 3.00 m ?

Solution for Problem 27

28. As shown on the right a construction crane is raising three components up to a skyscraper work area as the skyscraper is being build. The mass of each component is $m_C = 1400.$ kg, $m_B = 2300.$ kg, and $m_A = 3100.$ kg. The top cable which has its tension labeled as T_{ABC} has a maximum strength of 8.50×10^4 N, while the two cables below labelled as T_{BC} and T_C have a maximum strength of 4.25×10^4 N.

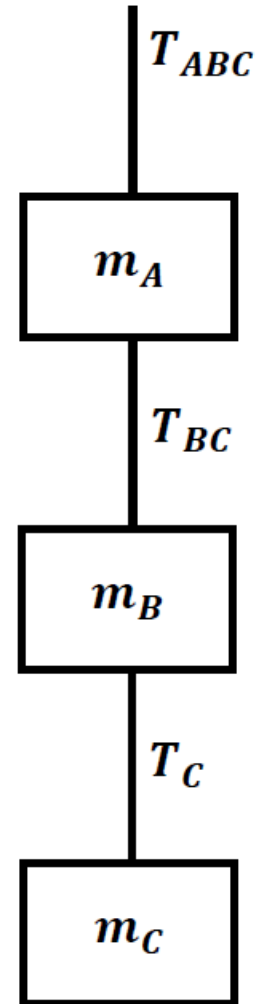

- (a) What is the tension in each of the three cables T_{ABC} , T_{BC} , T_C if the components are raised at a constant speed?
- (b) What is the greatest acceleration that can be used to raise the three components without any of the three cables breaking?

Solution for Problem 28

29. Recently NASA has been experimenting with launching objects at large rocks (“Asteroids”) that if they were to strike Earth could damage or even cause the extinction of most forms of life on the planet such as the asteroid which likely began the decline of the dinosaurs about 65 Million years ago. So, consider a rock with a mass of 5.00×10^{10} kg moving to collide with Earth in the future. NASA or SPACEX sends a space probe with a rocket thruster. When the probe gets attached to the rock the thruster can be turned on. Assume a change of the rock’s speed by as little as 3.00×10^{-3} m/s will change the path of the rock enough that it will not collide with the Earth. If the thruster can deliver a thrust force as small as 4.25 N, how long would the thruster need to act to achieve the change in speed sufficient to alter the path of the rock and save the Earth?

Solution for Problem 29

30. Two delivery workers are moving a Hammond Organ down the ramp from the delivery truck. The organ has a mass ($m_{\text{organ}} = 193. \text{ kg}$) and is on a furniture dolly which has frictionless wheels. The ramp makes an angle ($\theta = 13.0^\circ$) with horizontal. The ramp has a length of 12.7 m. The two workers manage to provide a force ($F_{\text{workers}} = 390. \text{ N}$) which is directed parallel to and up the ramp to oppose gravity acting down the ramp. Assume the organ is at rest at the top of the ramp, what is the speed it has at the bottom of the ramp?

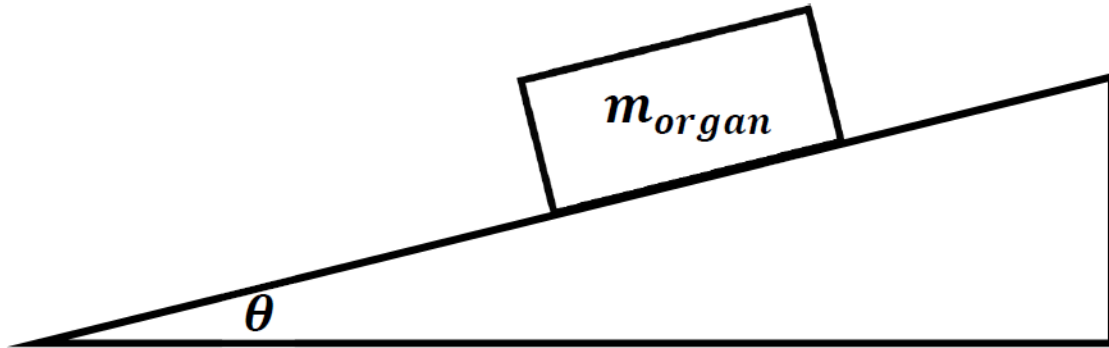

Solution for Problem 30

31. Two masses are shown below. m_T (2.33 kg) sits on top of m_B (6.19 kg). There is a cable connecting the two masses. The cable is massless, stretchless, and unbreakable. The cable passes over a massless frictionless pulley. There is no friction between the two masses or between the bottom mass and the floor. A force P is applied to the bottom mass.

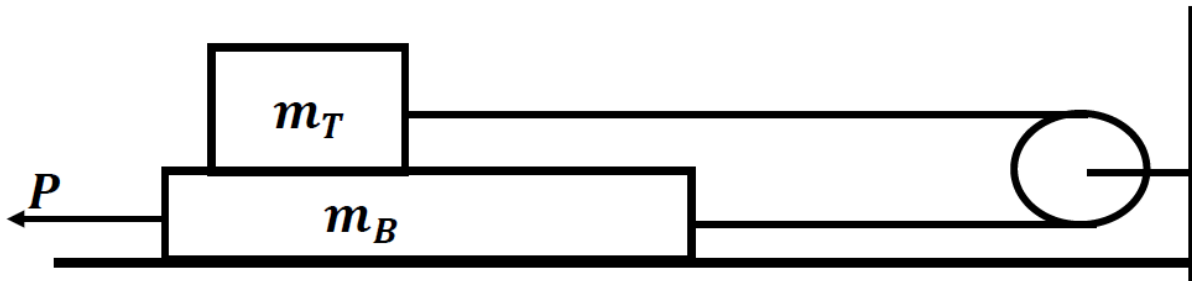

- (a) What is the magnitude of force P needed to provide the top mass with an acceleration of 3.13 m/s^2 to the right?
- (b) What is the tension in the cable when the top mass has the acceleration of 3.13 m/s^2 ?

Solution for Problem 31

NMU Physics
Department Web
Page

NMU Main Page

Please send any comments or questions about this page to
ddonovan@nmu.edu

This page last updated on February 5, 2024