

## PH 220 Homework Assignment Chapter on Conservation of Momentum – 32 Problems Total

1. A constant friction force of 35.8 N acts on a snowboarder who has a mass of 73.2 kg for a time of 21.7 s. What is the change in the snowboarder's velocity?

### Solution for Problem 1

2. The force on a particle of mass  $m$  is given by

$$\vec{F} = -16.0t \hat{i} + 23.0t^2 \hat{j}$$

Where force is in newtons when time is in seconds. What is the change in the particle's momentum between time  $t_0 = 1.40$  s and  $t_f = 2.80$  s?

### Solution for Problem 2

3. A spaceship ( $m_{\text{ship}} = 4290$ . kg) is moving in outer space with a velocity  $\vec{v}_0 = 132$ . m/s  $\hat{i}$ . To change its flight trajectory by an angle ( $\theta = 38.0^\circ$ ) a quantity of rocket fuel is expelled with a velocity  $\vec{v}_{\text{Gas}} = 1670$ . m/s  $\hat{j}$ . This creates the change in velocity  $\Delta\vec{v}$  needed to make the course change. What is the mass of the gas ejected to make this work?

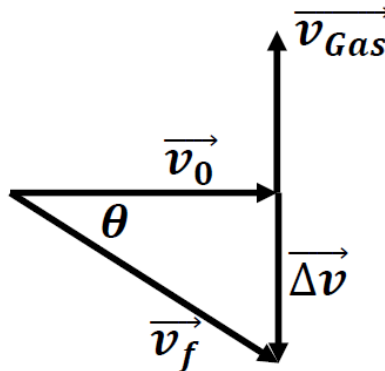

### Solution for Problem 3

4. A series of level water troughs are used to move logs that have been cut to the processing building where the logs will be cut into useful chunks of wood to be sold. A 200. kg log is moving with a speed of 4.58 m/s relative to the water. A worker ( $m_{\text{person}} = 72.3$  kg) steps onto the moving log from the side with no velocity relative to the water. What is the speed of the log and the person after the person has gotten onto the log?

### Solution for Problem 4

5. An atom has an atomic mass of 237. U and is moving with a speed of  $500. \text{ m/s}$ . U means atomic mass units and  $1 \text{ U} = 1.66 \times 10^{-27} \text{ kg}$ . The atom spontaneously emits an alpha particle which has a mass ( $m_\alpha = 4.00 \text{ U}$ ) and the alpha particle has a speed of  $4500. \text{ m/s}$  in the same direction as the original atom. What is the speed of the new atom?

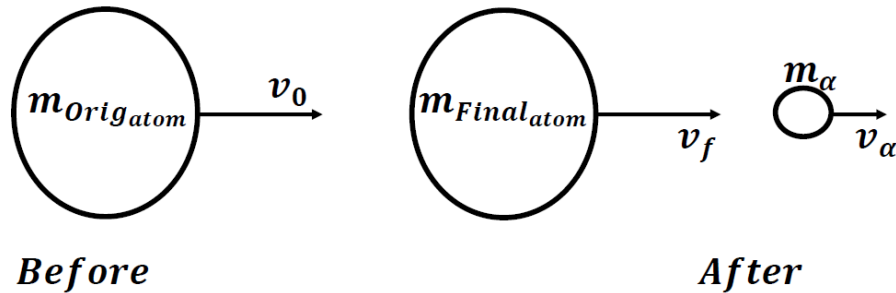

**Solution for Problem 5**

6. A block of wood ( $m_{\text{block}} = 3.00 \text{ kg}$ ) is at rest on a frictionless horizontal surface. A bullet ( $m_{\text{bullet}} = 2.23 \times 10^{-3} \text{ kg}$ ) is travelling with a speed of  $v_{\text{bullet } 0} = 240. \text{ m/s}$  when it strikes the block and after penetrating it, the bullet exits with a final speed of  $v_{\text{bullet } f} = 170. \text{ m/s}$ . What is the final speed of the wood block after the bullet exits from it?

**Solution for Problem 6**

7. A mass ( $m_1 = 4.00 \text{ kg}$ ) has an initial velocity given by  $\vec{v}_{10} = (5.00 \hat{i}) + 3.75 \hat{j} - 4.90 \hat{k}) \text{ m/s}$  and then it strikes a second mass ( $m_2 = 2.63 \text{ kg}$ ), which is initially at rest. Assume this event occurs in space with no other masses nearby and hence there are no outside forces acting. After the collision, the first mass has a final velocity of  $\vec{v}_{1f} = (5.00 \hat{i}) - 2.56 \hat{j} + 1.07 \hat{k}) \text{ m/s}$ . What is the final velocity of mass 2?

**Solution for Problem 7**

8. A major league pitcher throws a baseball ( $m_{\text{ball}} = 0.145 \text{ kg}$ ) with a velocity of  $\vec{v}_0 = 39.3 \text{ m/s} (-\hat{j})$ . The batter makes good contact with the bat in touch with the ball for a time of  $4.45 \times 10^{-3} \text{ s}$ . This results in a final velocity of the ball as  $\vec{v}_f = 66.6 \text{ m/s} (+\hat{j})$ . What was the average force the bat exerted on the baseball?

**Solution for Problem 8**

9. A rubber ball has a mass of ( $m_{\text{ball}} = 0.125 \text{ kg}$ ) and a velocity of  $17.9 \text{ m/s}$  @  $45.0^\circ$  above  $(-i)$ . After contacting the wall, the ball rebounds with a velocity of  $17.9 \text{ m/s}$  @  $45.0^\circ$  above  $(+i)$ . What is the magnitude and direction of the impulse imparted to the ball by the wall?

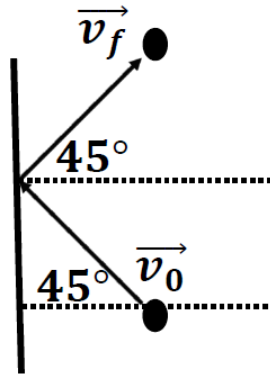

**Solution for Problem 9**

10. An average grain of rice has a mass of  $3.00 \times 10^{-5} \text{ kg}$ . A processing machine drops about 103. grains a second into a pan. The grains of rice are released from rest and they fall a distance of 0.500 m before they hit the bottom of the pan they collect in. Assume the rice grains do not rebound off the pan bottom. They just stop (i.e.  $v_f = 0$ ). Assume no air resistance (yes, this is a horrible assumption for rice, but the mathematics are not worth it for this problem). Determine the average force the bottom of the pan experiences from the rice striking the bottom of the pan?

**Solution for Problem 10**

11. A solid colored marble ( $m_1 = 0.016 \text{ kg}$ ) is moving(rolling) with a speed  $v_{10}$  when it strikes a striped marble which is initially at rest. The second marble moves off with half the speed ( $v_{2f} = \frac{v_{10}}{2}$ ) of the original marble which is still moving, though with a different speed. Assume the collision is an elastic one.

- (a) What is the mass of the second marble?
- (b) What fraction of the original kinetic energy ( $\frac{K_2}{K_{\text{before}}}$ ) is transferred to the second marble?

**Solution for Problem 11**

**12.** A block of mass ( $m_1 = m$ ) is sliding on a horizontal frictionless surface. It collides with a second block of mass ( $m_2$ ) which is at rest. Block 1 rebounds off of block 2 and moves back along its original path but with only 35% ( $0.350 v_{10}$ ) of the original speed it had. Block 2 moves off. The collision is an elastic collision. What is the mass of block 2 relative to block 1?

**Solution for Problem 12**

**13.** Find the expressions for a general head-on one-dimensional elastic collision that provide the final speeds based on the initial speeds and the masses of two objects  $m_1$ ,  $v_{10}$ ,  $m_2$ , and  $v_{20}$ .

**Solution for Problem 13**

**14.** A ballistic pendulum is a set-up pictured below which, allows the determination of a gun's muzzle velocity. A gun fires a bullet ( $m_{\text{Bullet}}$ ) which has a muzzle velocity shown below as  $v_{0 \text{ Bullet}}$ . The bullet strikes and penetrates a large block of wood with a mass  $m_{\text{Block}}$ . The block is initially hanging at rest. After the bullet is buried in the block, the combined block and bullet move off. Since the block is attached by a stretchless, massless, unbreakable cord to the ceiling, the block and bullet act as a bob on a pendulum and therefore rises a height  $h$  above the original hanging position. The height is reached as the kinetic energy of the block and bullet get transformed into gravitational potential energy. By measuring the masses of the block and bullet and finding that height, you can determine the muzzle velocity of the bullet.

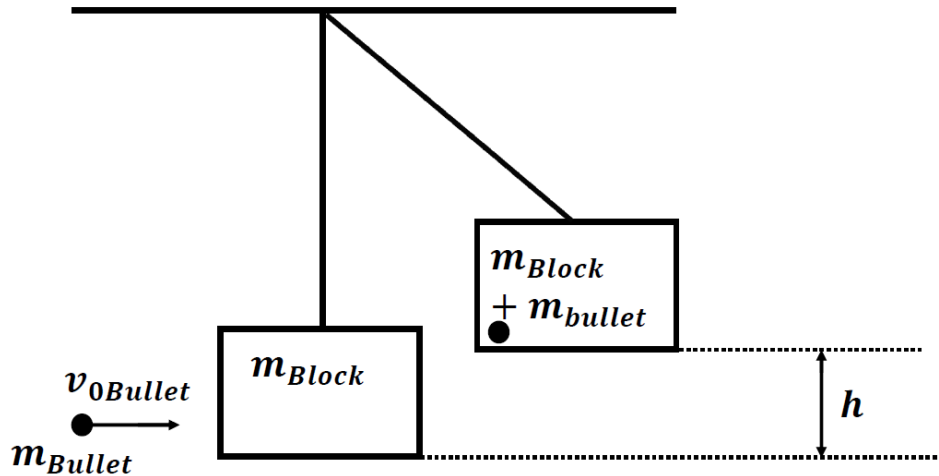

- (a) Determine the expression for the muzzle velocity ( $v_{0 \text{ Bullet}}$ ) in terms of  $m_{\text{Bullet}}$ ,  $m_{\text{Block}}$ , and  $h$ .
- (b) Determine the expression for the fraction of energy lost in the collision of the bullet and the block  $\frac{\Delta K}{K_0} = \frac{\frac{1}{2}m_{\text{Bullet}}v_{0 \text{ Bullet}}^2 - \frac{1}{2}(m_{\text{Bullet}}+m_{\text{Block}})v_f^2}{\frac{1}{2}m_{\text{Bullet}}v_{0 \text{ Bullet}}^2}$  in terms of  $m_{\text{Bullet}}$ ,  $m_{\text{Block}}$ , and  $h$ .
- (c) Find the numerical value of muzzle velocity if  $m_{\text{Bullet}} = 0.020 \text{ kg}$ ,  $m_{\text{Block}} = 5.00 \text{ kg}$ , and  $h = 8.50 \times 10^{-2} \text{ m}$ .
- (d) Find the numerical value of fraction of energy lost if  $m_{\text{Bullet}} = 0.020 \text{ kg}$ ,  $m_{\text{Block}} = 5.00 \text{ kg}$ , and  $h = 8.50 \times 10^{-2} \text{ m}$ .

**Solution for Problem 14**

15. A Toyota Prius with its driver has a mass ( $m_P = 1522. \text{ kg}$ ) and is driving along with a speed ( $v_{0P} = 27.8 \text{ m/s}$ ) when it collides with a Chevy Suburban with a driver and passenger has a mass ( $m_S = 3578. \text{ kg}$ ). The Suburban is at rest and its brakes are locked on. After the collision the vehicles, which are stuck together slide down the pavement for a distance of 6.870 m. What is the coefficient of kinetic friction between the tires and the pavement?

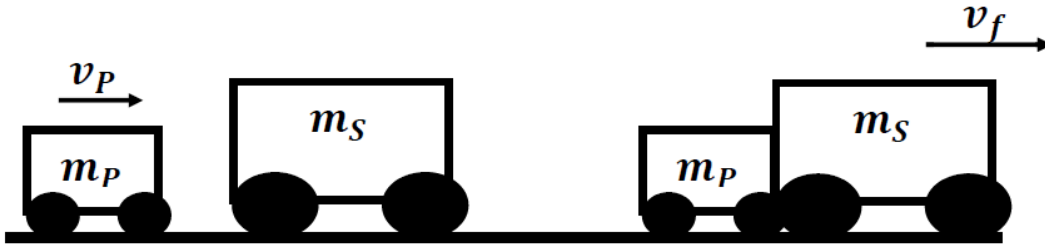

**Solution for Problem 15**

16. A ballistic pendulum consists of a cup with a solid arm of length  $L$  and a mass of  $m_2$ . The pendulum is hanging at rest at the bottom. A projectile of mass  $m_1$  and initial speed of  $v_0$ . The projectile is caught in the cup and the whole pendulum swings upward in a circular arc of radius  $L$ . Determine an expression for the minimum speed  $v_0$  that will just allow the pendulum to reach the top of the arc.

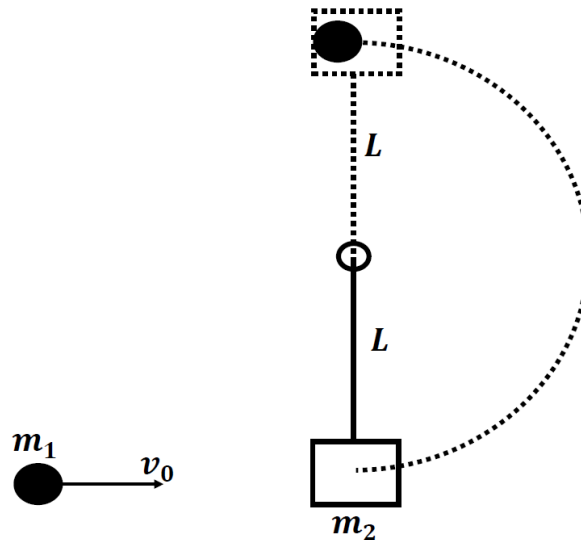

**Solution for Problem 16**

**17.** A mass ( $m_1 = 0.288 \text{ kg}$ ) is moving through the air with a velocity of  $\vec{v}_{10} = 29.4 \text{ m/s}$  (East) strikes a mass ( $m_2 = 6.11 \text{ kg}$ ) which is sitting at rest on a frictionless coaster. After the mass  $m_1$  strikes  $m_2$ , mass  $m_1$  rebounds with a velocity of  $\vec{v}_{1f} = 13.2 \text{ m/s}$  (West). Mass  $m_2$  moves off with a velocity  $\vec{v}_{2f}$ .

- (a) Determine the velocity  $\vec{v}_{2f}$ .
- (b) Calculate the total initial kinetic energy.
- (c) Calculate the total final kinetic energy.

**Solution for Problem 17**

**18.** A radioactive nucleus at rest decays into a second nucleus, an electron and a neutrino. The electron and the neutrino are emitted at right angles and have momenta of  $p_{e^-} = 9.6 \times 10^{-23} \text{ kg m/s}$  and  $p_{\nu_e} = 6.2 \times 10^{-23} \text{ kg m/s}$ . Determine the magnitude and direction of the recoil momentum of the second nucleus.

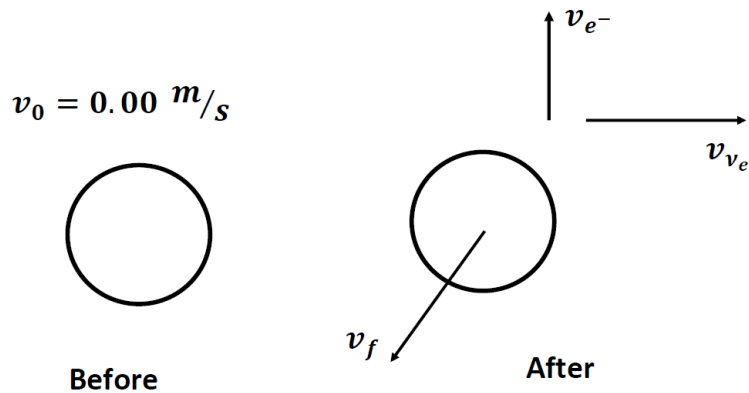

**Solution for Problem 18**

19. Mass A has a mass ( $m$ ) and moves along the  $y$  axis with a velocity of ( $v_{A0} = 4.30 \text{ m/s } \widehat{(+y)}$ ). Mass B has a mass ( $m$ ) and moves along the  $x$  axis with a velocity of ( $v_{B0} = 3.70 \text{ m/s } \widehat{(+x)}$ ). At the origin the two masses elastically collide and mass B results in a velocity ( $v_{Bf} = 4.30 \text{ m/s } \widehat{(+y)}$ ). Determine the final velocity of mass A.

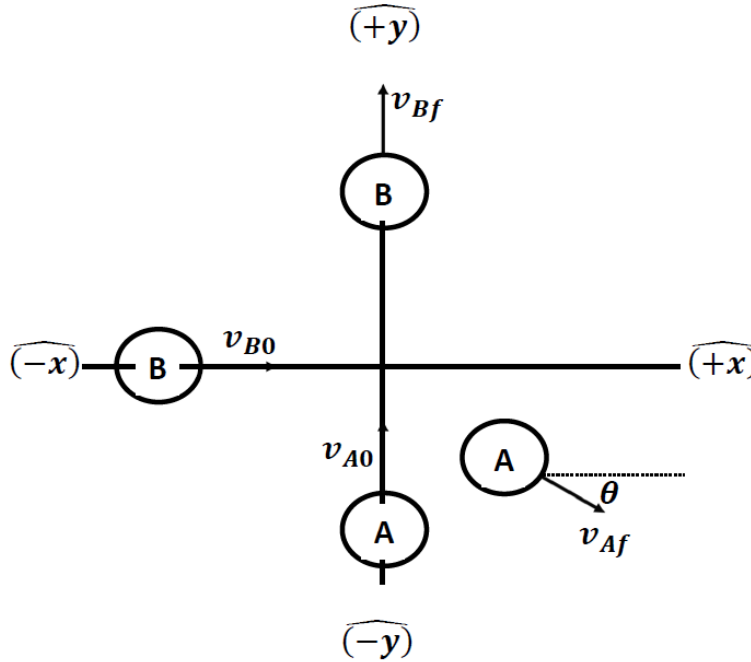

**Solution for Problem 19**



**20.** A neutron collides elastically with a helium nucleus, which is at rest before the collision. The mass of the helium nucleus is four times the mass of a neutron. The initial speed of the neutron is  $6.20 \times 10^5 \text{ m/s}$ . After the collision the helium nucleus moves off with an angle of  $\theta_{\text{He}} = 45.0^\circ$ . The situation is pictured below.

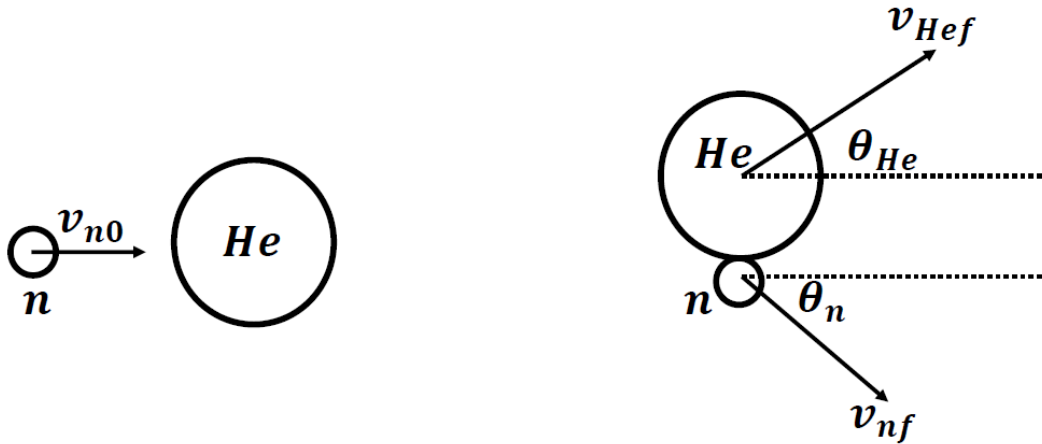

- (a) Determine the final speed of the Helium nucleus ( $v_{\text{He}f}$ ).
- (b) Determine the final speed of the neutron ( $v_{\text{n}f}$ ).
- (c) Determine the angle of the neutron ( $\theta_n$ ).

**Solution for Problem 20**

**21.** The distance between the Nitrogen atom ( $m_{\text{N}} = 14.0 \text{ U}$ ) and the Oxygen atom ( $m_{\text{O}} = 16.0 \text{ U}$ ) in a NO molecule is  $1.15 \times 10^{-10} \text{ m}$ . How far is the Nitrogen atom from the center of mass of the molecule?

**Solution for Problem 21**

22. Three masses are sitting next to each other as shown below. They are all made of the same material and have a uniform mass density. They are aligned along a center line as shown. The left most one is a cube of side length  $L$ , the middle one is a cube a side of length  $2L$ , and the right most one is a cube of length  $3L$ . Where is the center of mass along the  $x$  axis?

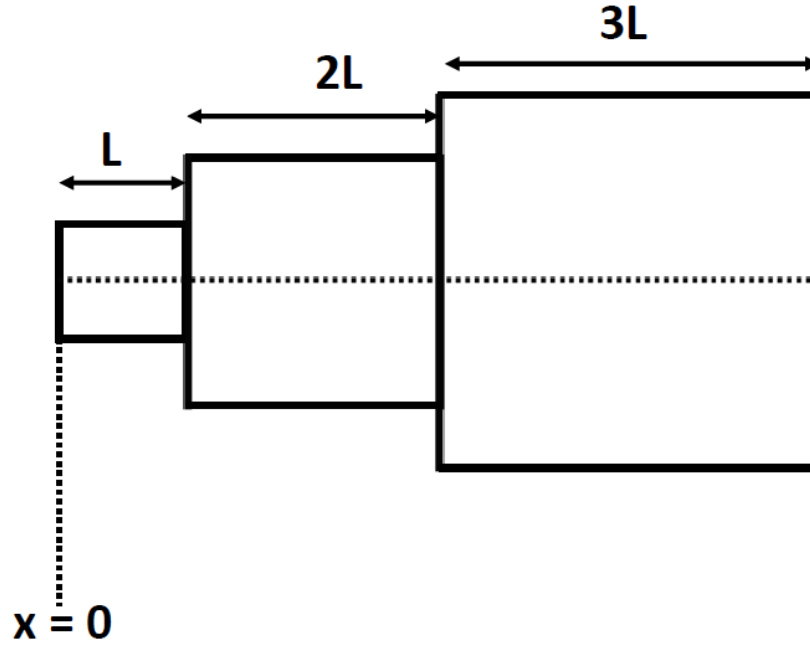

Solution for Problem 22

23. A circular plate is made from a material whose mass is uniformly distributed. The plate has a radius of  $4R$ . The plate has two circular holes which have radius  $R$ . The right one is centered at  $3R$  to the right of the center of the large plate, while the left one is centered  $R$  to the left of the center of the large plate. See the diagram below. Where is the center of mass along the horizontal axis relative to the center of the large plate?

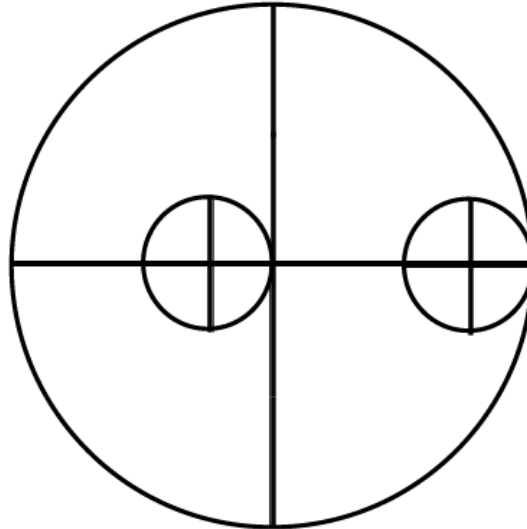

Hint: Consider the two small circles as negative mass.

**Solution for Problem 23**

24. An ammonia molecule is composed of three hydrogen atoms that sit on the vertices of an equilateral triangle with a side length ( $L = 0.16 \text{ nm}$ ). The nitrogen atom sits atop the apex of the pyramid formed with a height ( $h = 0.037 \text{ nm}$ ) above the triangle's center of mass. Find the center of mass for the whole molecule. Use the masses  $m_H = 1.008 \text{ U}$  and  $m_N = 14.007 \text{ U}$ .

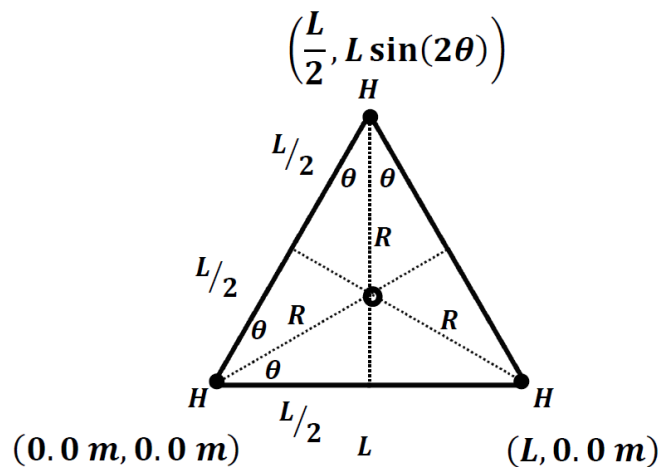

**Solution for Problem 24**

25. Find the center of mass of a solid cone shown below. The top piece is a circle of radius  $R$  and the cone is length of  $h$ . The mass is uniformly distributed throughout the cone which has a total mass of  $M$ .

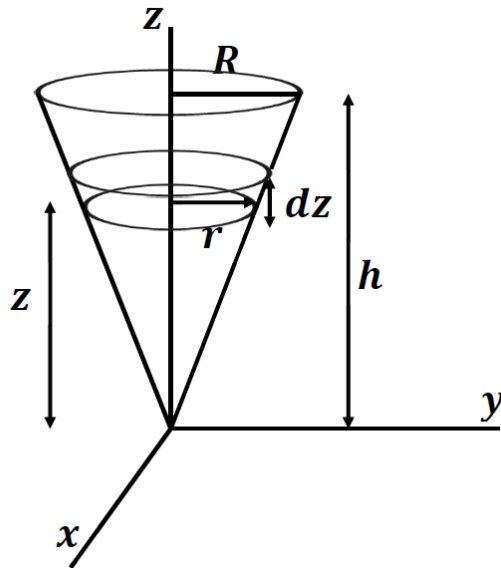

**Solution for Problem 25**

26. Two masses make up a system. Mass 1 ( $m_1 = 44.4$  kg) has a velocity given by  $\vec{v}_1 = (-16.0 \hat{i} + 12.0 \hat{j})$  m/s and mass 2 ( $m_2 = 33.3$  kg) has a velocity given by  $\vec{v}_2 = (14.0 \hat{i} - 20.0 \hat{j})$  m/s. Determine the velocity of the center of mass for this system.

**Solution for Problem 26**

27. A man and his daughter are standing on the ice (assume no friction) about 13.0 m apart. The daughter has a mass ( $m_d = 34.8$  kg) while the father has a mass ( $m_f = 78.3$  kg). The father has tied a rope around his daughter's waist as a safety line. Assume the rope has no mass, cannot stretch and will not break.

- (a) Relative to the daughter, where is the center of mass for the father and daughter?
- (b) The father pulls on the rope drawing the daughter to him. How far has the daughter moved when the father has moved 1.45 m?
- (c) The daughter at this time starts to pull on the rope as well. How far from her original point will the father have moved when he and his daughter are together on the ice?

**Solution for Problem 27**

**28.** Doug and Sue go out in a canoe which allows them to sit 3.50 m apart. Doug has a mass ( $m_{\text{Doug}} = 82.4 \text{ kg}$ ) and he is in the easternmost seat. Sue has a mass of ( $m_{\text{Sue}} = 52.7 \text{ kg}$ ) and she is of course in the westernmost seat. The canoe is at rest on the lake and the water is calm. They decide to switch seats. How far and in which direction does the canoe move between their original seats and when they finish switching?

**Solution for Problem 28**

**29.** During a severe storm (say, Cat 3 hurricane) wind speeds can exceed  $58.0 \text{ m/s}$ . This can result in a mass of air striking a person of approximately  $63.6 \text{ kg/s}$ . Assume a person has a height of 1.70 m and an average width of 0.280 m. Assume the mass of air is brought to rest when it strikes the person.

- (a) What is the average force impacting the person?
- (b) If one assumes a maximum coefficient of static friction of  $\mu_s = 1.00$ , what is the maximum static friction force a person of mass ( $m = 75.0 \text{ kg}$ ) could have between their shoes and the ground?

**Solution for Problem 29**

**30.** An open rail car has a mass of 3600. kg is traveling along a horizontal level of track with a speed of  $6.60 \text{ m/s}$ . It begins to rain and water begins to fill the car with a rate of  $4.23 \text{ kg/min}$ . Ignoring frictional effects with the rails, what is the speed of the car after two hours have passed. Assume the rain is constant and vertical during this time.

**Solution for Problem 30**

**31.** Two balls A and B hang on identical length string and when they are at rest, their sides just touch as shown in the figure below. Mass for A ( $m_A = 0.590 \text{ kg}$ ) and mass for B ( $m_B = 0.780 \text{ kg}$ ). The cord length is ( $L = 0.685 \text{ m}$ ). Mass A is raised to an angle ( $\theta = 56.0^\circ$ ). Mass A is released from rest. It will collide with mass B in an elastic collision.

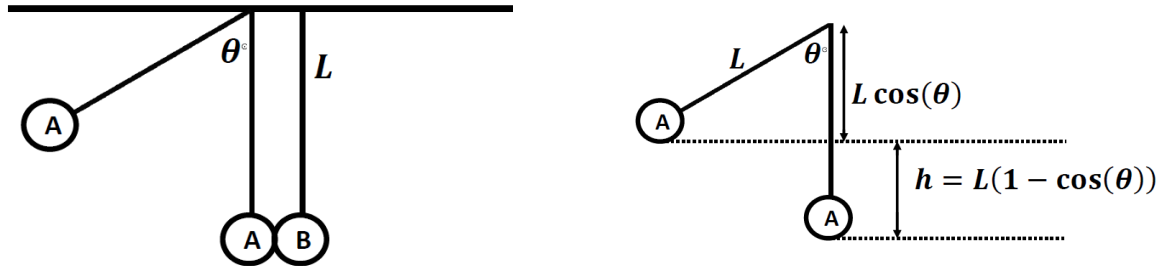

- What is the speed of A just before it collides with B?
- What is the speed of A just after it collides elastically with B?
- What is the speed of B just after it was hit elastically by A?
- How high will B rise before it begins to fall back down?
- How high will a rise before it begins to fall back down?

**Solution for Problem 31**

**32.** A comet has a mass of  $1.07 \times 10^{12} \text{ kg}$  and a speed of  $6.14 \times 10^4 \text{ m/s}$ . The Earth has a mass of  $5.98 \times 10^{24} \text{ kg}$  and an orbital speed of  $2.98 \times 10^4 \text{ m/s}$  as it orbits the Sun.

- Assume the comet strikes the Earth in a head-on collision and the comet comes to rest on Earth. What is the final speed of the Earth in its orbit?
- Assume the Earth is at rest and the comet again strikes the Earth and comes to rest on the Earth. What is the recoil speed of the Earth?

**Solution for Problem 32**

---

NMU Physics  
Department Web  
Page

---

NMU Main Page

Please send any comments or questions about this page to  
[ddonovan@nmu.edu](mailto:ddonovan@nmu.edu)

*This page last updated on March 13, 2024*