

PH 221 Homework Assignment Chapter on DC Circuits – 21 Problems Total

1. A battery can be thought of as internal emf (ϵ) and an internal resistance (R_{Internal}). As shown below there is then a terminal voltage (V_{Terminal}). For this battery emf is ($\epsilon = 12.0 \text{ V}$) and the internal resistance is ($R_{\text{Internal}} = 0.750 \Omega$).

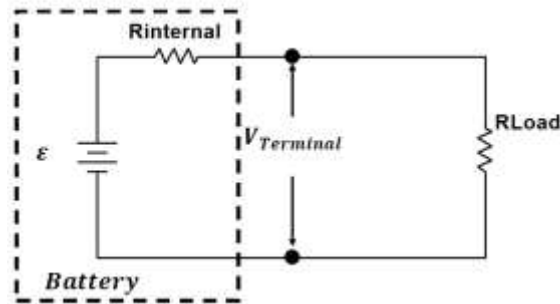

- (a) Calculate the terminal voltage of the battery if the load resistor is ($R_{\text{Load}} = 63.0 \Omega$).
- (b) Calculate the terminal voltage of the battery if the load resistor is ($R_{\text{Load}} = 1260. \Omega$).

Solution for Problem 1

2. As shown in the circuit below, two resistors ($R_1 = 330. \Omega$, $R_2 = 170. \Omega$) are connected in series with each other and a voltage source ($V_s = 15.0 \text{ V}$). What is the voltage across the (R_1) ?

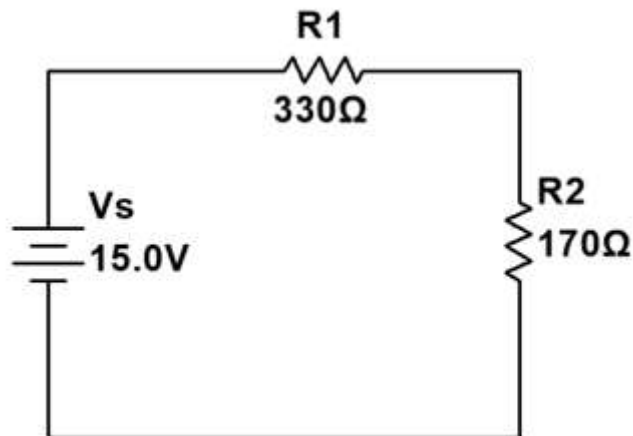

Solution for Problem 2

3. You have three resistors: ($R_1 = 1200. \Omega$), ($R_2 = 620. \Omega$), and ($R_3 = 2700. \Omega$).
- (a) How should you connect these three resistors to get the largest resistance?
- (b) How should you connect these three resistors to get the lowest resistance?

Solution for Problem 3

4. How many 5.00Ω resistors must be connected in series, to equal two $100. \Omega$ resistors wired in parallel?

Solution for Problem 4

5. As shown in the circuit below, a battery with an emf of 12.0 V shows a terminal voltage of 11.6 V when two identical light bulbs are connected in parallel. Each of the light bulbs is rated at 60.0 W at 12.0 V . What is the internal resistance (r_{Int}) of the battery?

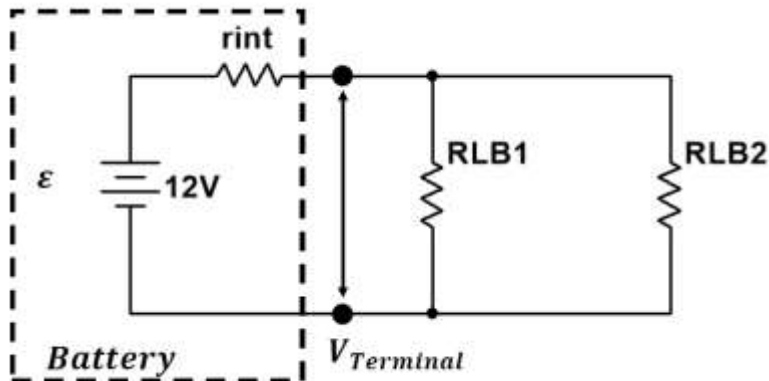

Solution for Problem 5

6. Consider the circuit shown below:

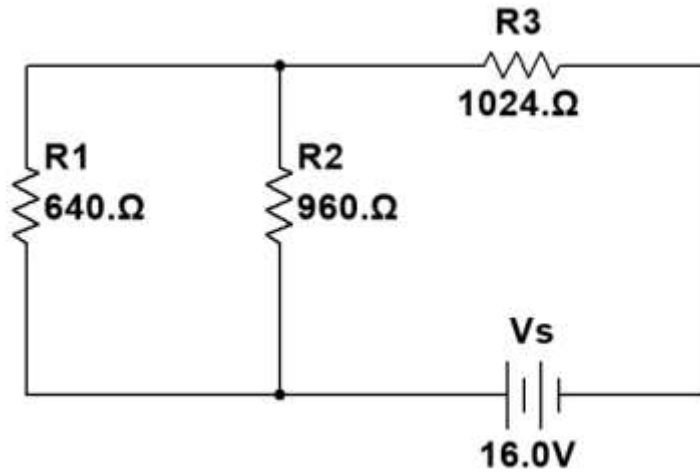

- (a) Determine the total resistance across the voltage source.
- (b) Calculate the voltage across the resistor R_3 .
- (c) Calculate the voltage across the resistor R_2 .
- (d) Calculate the voltage across the resistor R_1 .

Solution for Problem 6

7. In the circuit below, the resistors have the values: $R_1 = 120. \Omega$, $R_2 = 240. \Omega$, $R_3 = 360. \Omega$, $R_4 = 300. \Omega$, $R_5 = 480. \Omega$, and $R_6 = 560. \Omega$. The voltage is $V_S = 20.0 \text{ V}$. How much current is drawn from the power source?

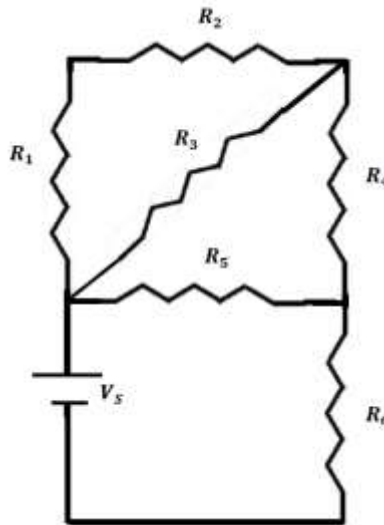

Solution for Problem 7

8. Two resistors are wired in series with a power source ($V_S = 240. \text{ V}$). In this combination they use one-fifth of the power they use when the same two resistors are wired in parallel. If $R_1 = 1200. \Omega$, what is the value of the other resistor R_2 ?

Solution for Problem 8

9. Consider the circuit shown below:

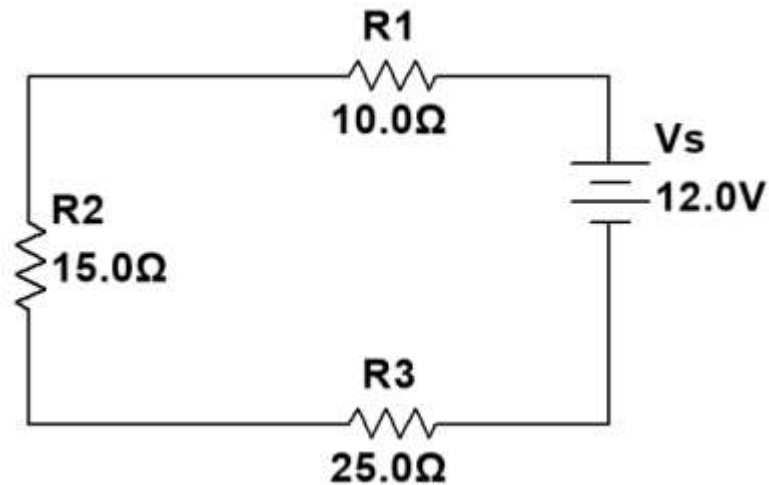

- (a) Calculate the current flowing through the circuit.
- (b) Demonstrate that the sum of the voltage changes going around the circuit equals zero as it should.

Solution for Problem 9

10. For the circuit shown below, $R = 120. \Omega$ and $V = 13.0 \text{ V}$.

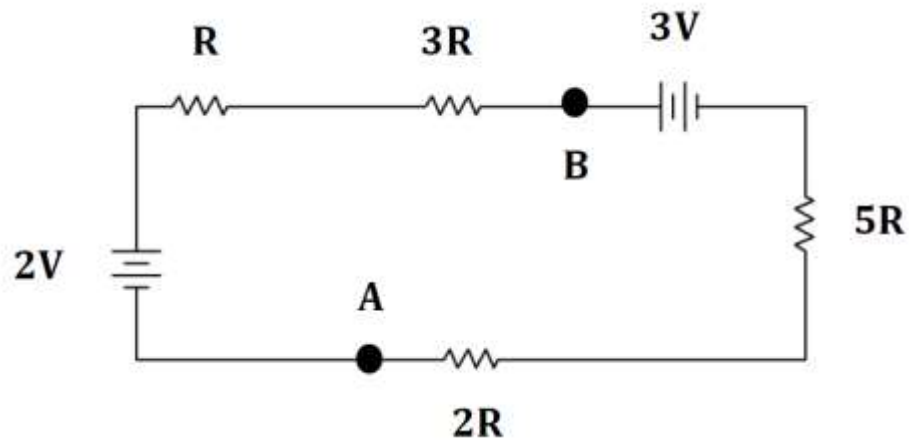

- (a) Determine the change in voltage going from Point A to Point B.
- (b) Which point is at the higher electric potential?

Solution for Problem 10

11.

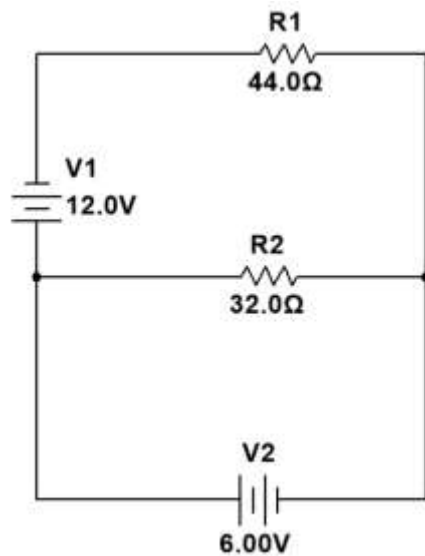

- (a) Determine the magnitude and direction of the current going through resistor R_1 .
- (b) Determine the magnitude and direction of the current going through resistor R_2 .

Solution for Problem 11

12. A voltage source (V_S) is applied to N identical resistors with resistance (R). The resistors are first connected in parallel with both each other and the voltage source. Second the resistors are connected in series with each other and the voltage source. What is the ratio of the power dissipated by the resistors in parallel to the power dissipated by the resistors in series $\frac{P_{\text{Parallel}}}{P_{\text{Series}}}$?

Solution for Problem 12

13. Consider the circuit below which contains three batteries A, B, and C each of which have a different EMF, but all have an internal resistance of 1.00Ω . Three currents have also been identified as i_1 , i_2 , and i_3 .

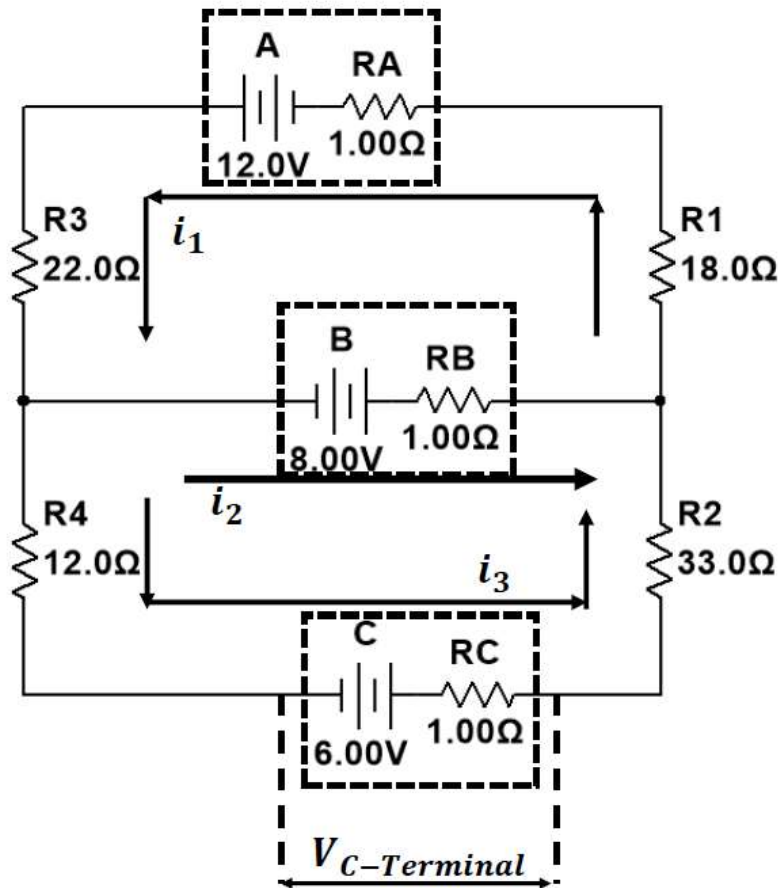

- (a) Determine the magnitude and direction of the current i_1 .
- (b) Determine the magnitude and direction of the current i_2 .
- (c) Determine the magnitude and direction of the current i_3 .
- (d) Determine the terminal voltage of Battery C.

Solution for Problem 13

14. As shown in the circuit below, two batteries are connected in parallel. Battery one has an emf of $\varepsilon_1 = 6.00 \text{ V}$ and an internal resistance of $r_{\text{int}1} = 1.56 \Omega$, While battery two has an emf of $\varepsilon_2 = 4.00 \text{ V}$ and an internal resistance of $r_{\text{int}2} = 1.42 \Omega$. What is the voltage across the load resistor?

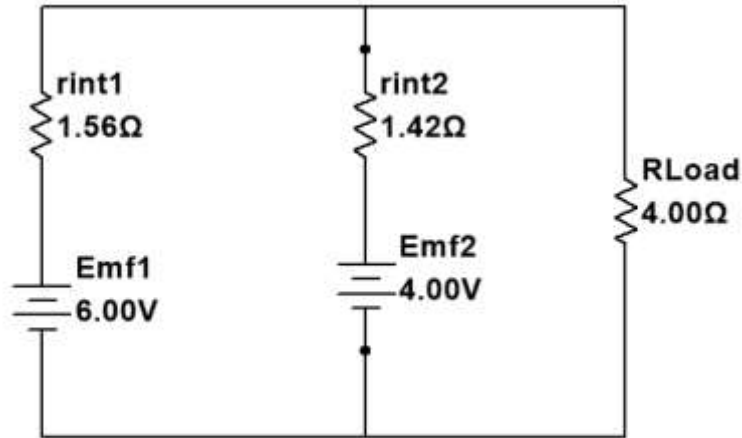

Solution for Problem 14

15. The circuit below shows a resistor and capacitor connected in series with a voltage source. The time constant for the RC circuit is 438. ms.

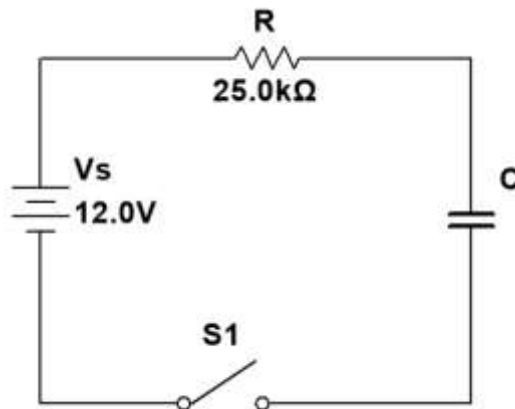

- (a) What is the capacitance of the capacitor?
- (b) How long after the switch is closed will it take for the voltage across the resistor to be 9.00 V?

Solution for Problem 15

16. A pacemaker helps a heart beat at a normal rate. Assume you wish to regulate a heart to beat with 80 beats/min. The pacemaker uses a simple RC circuit, with the capacitance used is $9.50 \mu\text{F}$. If the pacemaker is to fire when the voltage across the capacitor is 80% of its maximum value, what should the value of the resistance in this circuit be?

Solution for Problem 16

17. The circuit below is known as a “Wheatstone Bridge” circuit which is used to determine the resistance of an unknown resistance (R_x). The resistors (R_1) and (R_2) are precisely known resistors. (R_3) is a variable resistor which is adjusted until no current flows through the ammeter shown in the center of the bridge.

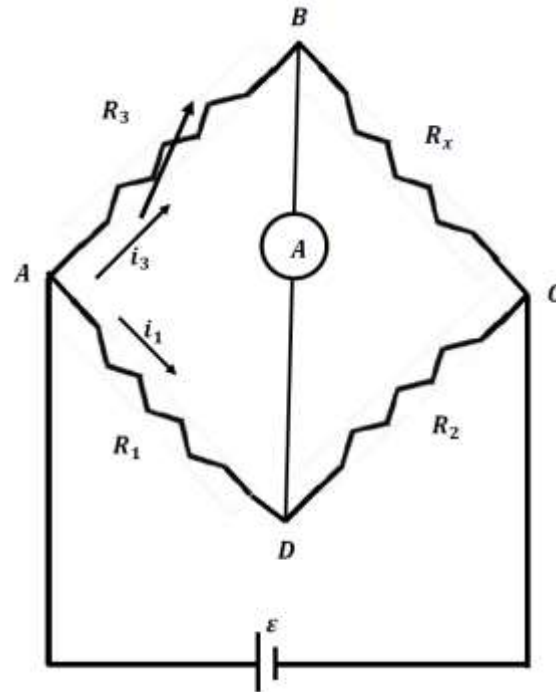

- (a) Find an expression that solves for the unknown resistance (R_x) in terms of the other resistors (R_1), (R_2), and (R_3).
- (b) What is the unknown resistance (R_x) if ($R_1 = 720. \Omega$), ($R_2 = 540. \Omega$), and ($R_3 = 95.4 \Omega$)?

Solution for Problem 17

18. A power supply is needed to provide a terminal voltage of 4.50 V. But the only available power source has a voltage output of 18.0 V. To get the desired terminal voltage a set of resistors are wired in series as shown below which is called a voltage divider.

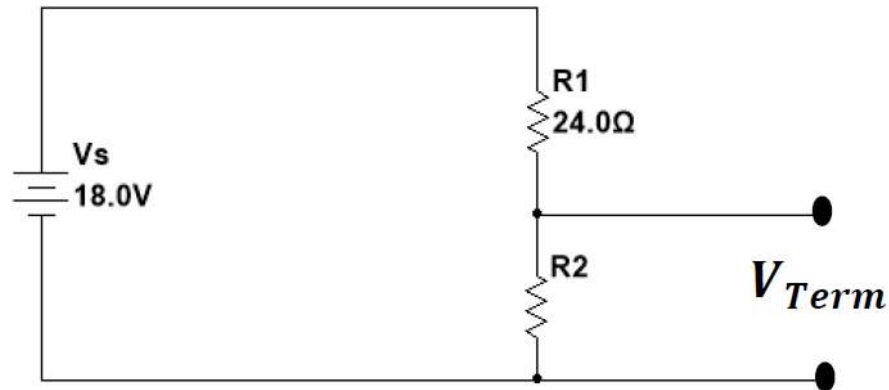

- (a) As shown $R_1 = 24.0 \Omega$, what value is needed for R_2 that will provide a terminal voltage $V_{Term} = 4.50 \text{ V}$.
- (b) A load resistor ($R_{Load} = 6.00 \Omega$) is placed across the terminal. What is the terminal voltage when the load resistance is in the circuit?

Solution for Problem 18

19. In the circuit shown below, it is determined that the 32.0 Ω resistor dissipates 0.402 W of power. What is the magnitude of the voltage provided by the power source?

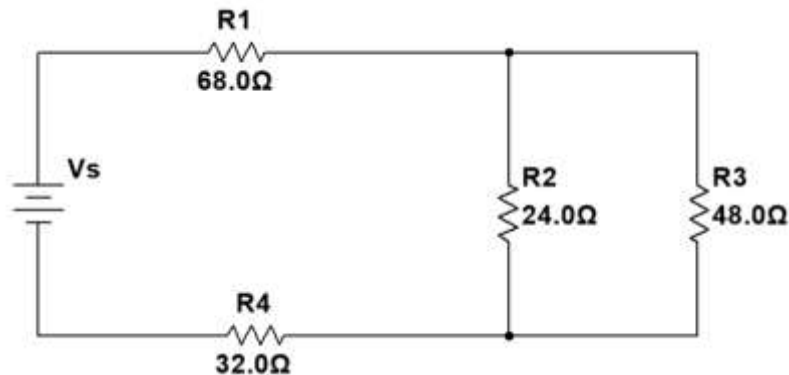

Solution for Problem 19

20. In the circuit shown below, the current in the $200. \Omega$ resistor does not change if the two switches are both open or both closed. What is the resistance not provided, it is labeled R?

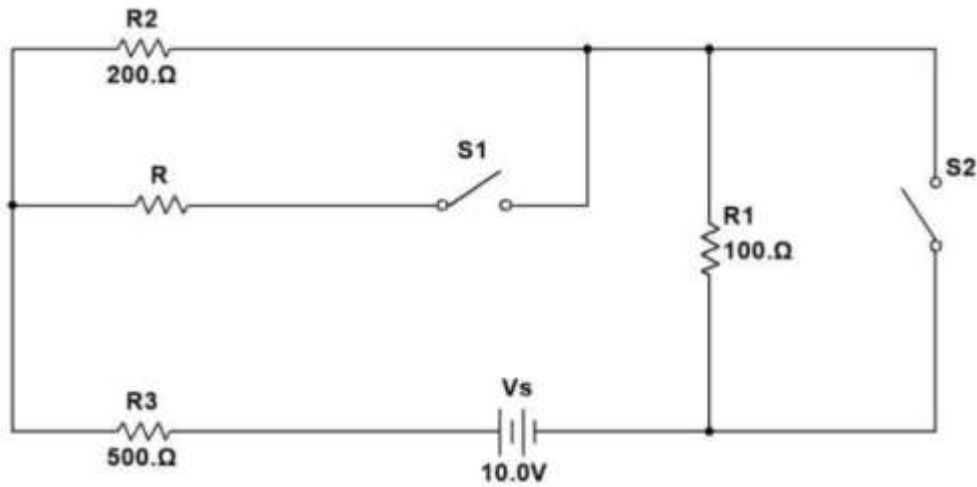

Solution for Problem 20

21. A light bulb is rated at $5.00 \text{ V} / 1.00 \text{ W}$ is wired up to a power supply (6.00 V) and a resistor is wired in series as shown below. What value should the resistor have for the light bulb to operate as it is rated?

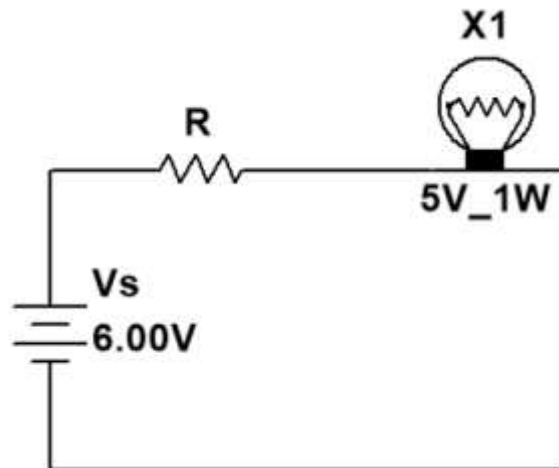

Solution for Problem 21

NMU Physics
Department Web
Page

NMU Main Page

Please send any comments or questions about this page to ddonovan@nmu.edu

This page last updated on September 8, 2024